

E5515C Fading Solution Application Guide for

W-CDMA Lab Application (E6703C, Revision C.01)

cdma2000 Lab Application (E6702B, Revision B.02)

1xEV-DO Lab Application (E6706A, Revision A.01)

<http://cp.literature.agilent.com/litweb/pdf/1000-1894.pdf>

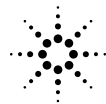

Agilent Technologies

Notice

Information contained in this document is subject to change without notice.

All Rights Reserved. Reproduction, adaptation, or translation without prior written permission is prohibited, except as allowed under the copyright laws.

This material may be reproduced by or for the U.S. Government pursuant to the Copyright License under the clause at DFARS 52.227-7013 (APR 1988).

Agilent Technologies, Inc.
Learning Products Department
24001 E. Mission
Liberty Lake, WA 99019-9599
U.S.A.

Contents

Product Description	5
Hardware and Software Checklist	7
How is a Faded Signal Generated?	8
What Fading Patterns are Available?	10
Operating Overview	12
Configuring the Fader System	13
Using the System Configuration Add Wizard	15
Selecting and Testing the System Configuration	21
Faded Test Example Procedures	24
Testing a cdma2000 Mobile Station with a Faded Channel	25
Testing a W-CDMA UE with a Faded Channel	38
Testing an 1xEV-DO Access Terminal with a Faded Channel	50
Fader System Requirements	65
Critical Fading Solution Settings	65
Power Level Control During Fading	67
Calibration	70
The Digital Bus Connection	73
Output Power	75
W-CDMA Transmitter Measurement Considerations	77
Position Location	79
GPIB Configuration	80
Troubleshooting	81
Known Issues	81
Other Considerations	82
Error Messages	82
Checking Fader Hardware Connectivity	82
Related Documentation	83

Product Description

The Agilent E5515C Fading Solution (referred to as “fader” throughout this document) provides a complete solution for performing faded signal tests on cdma2000, 1xEV-DO and W-CDMA mobile devices by integrating the base station emulation and measurement capability of the 8960 Wireless Communication Test Set (referred to as the “test set” throughout this document) with the digitally generated channel impairments generated by the N5115A Baseband Studio for Fading software (referred to as “fading software” throughout this document).

The primary components of the fader are a test set and a PC with a PCI fader circuit board and fading software.

The test set includes a hardware option that supports a digital interface to the PC for baseband signal data transfer between the devices.

Product Description

Figure 1. 8960 Fading Test Setup

Baseband Studio for Fading Software

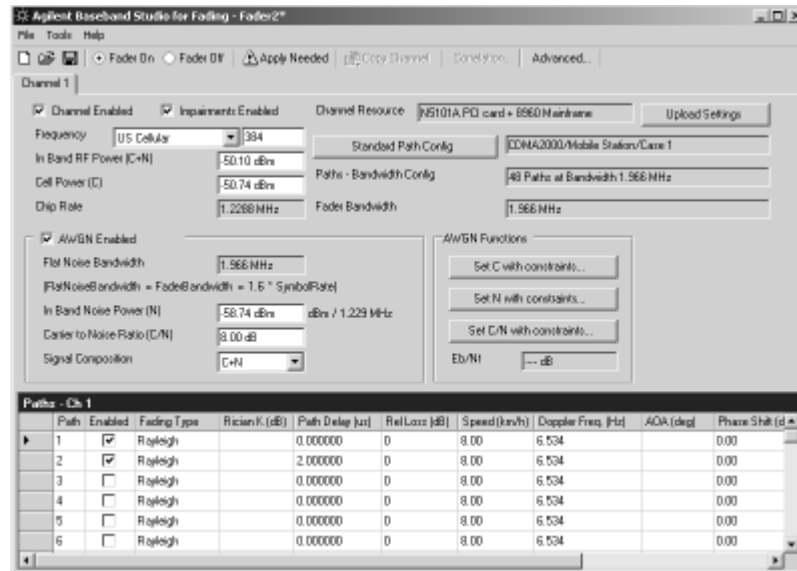

Baseband Studio
for fading software
(N5115A)

User's PC

Digital Baseband
I/Q Data

E5515C with
option 504

DUT

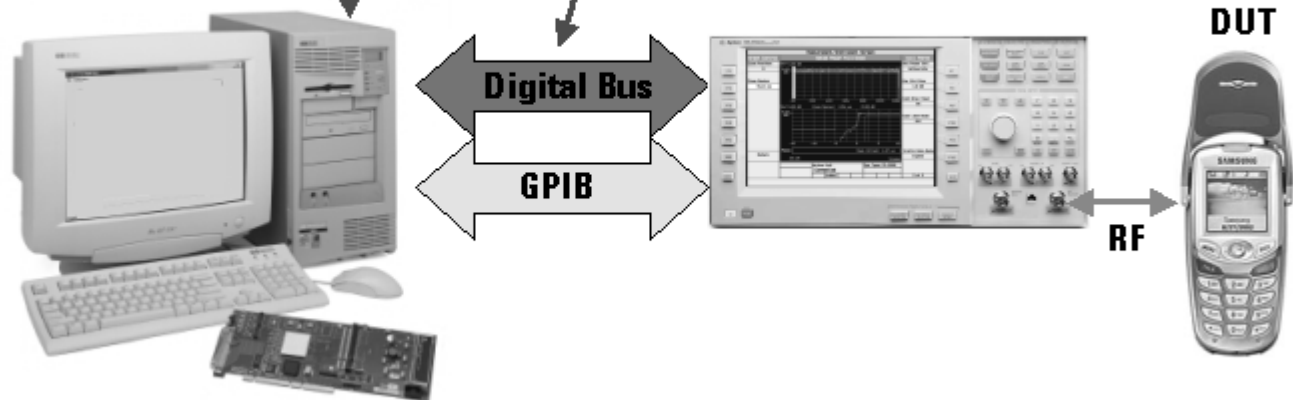

Baseband Studio PCI card N5101A

The GPIB (General Purpose Interface Bus) allows the fading software running on the PC to configure a number of settings on the test set when the user wants a faded signal.

When a faded signal from the test set is requested, the forward (or downlink) digital baseband signal from the test set is diverted to a PC equipped with the Baseband Studio PCI card via the test set's rear panel Digital Bus connector. The fading software, in conjunction with the PCI card, digitally integrates fading patterns and AWGN with the baseband signal.

The Digital Bus is an 80-pin bi-directional data interface. This bus is used to route the test set's digitized

baseband I/Q in the outgoing direction to the PC, and then route the incoming faded digital I/Q signal returning from the PC.

The Digital Bus is available only on test sets equipped with the E5515CU Option 504, Rear Panel Connector Kit and BBIO Board. See Figure 2. on page 7.

Figure 2. Test Set Rear Panel with Digital Bus

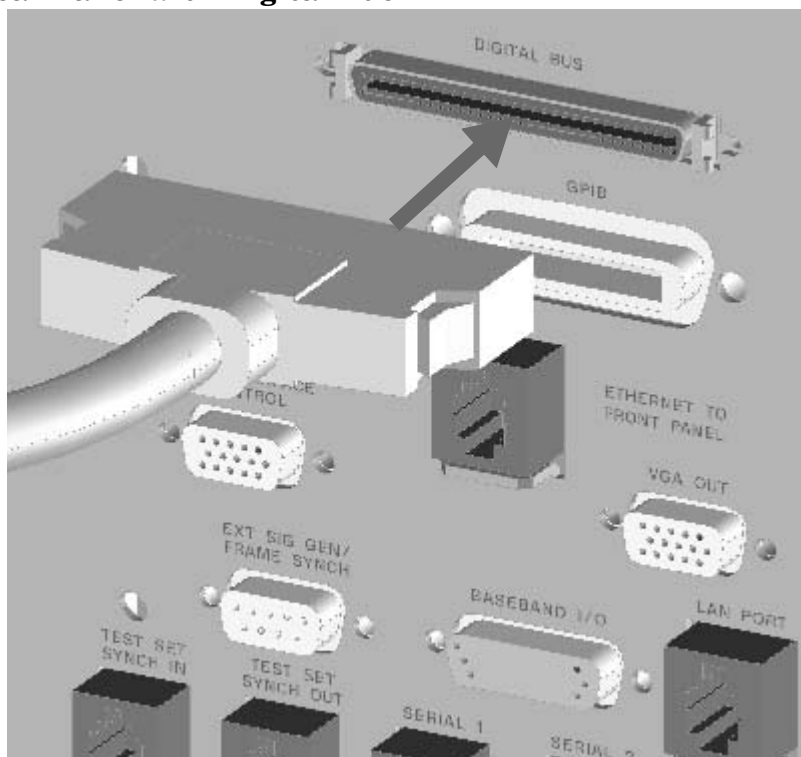

Hardware and Software Checklist

Below is a checklist of all hardware and software components and connections required for the test set and the PC:

NOTE Refer to the Baseband Studio Quick Start-Installation Guide for detailed setup instructions.

Test Set hardware and software

- E5515CU Wireless Communications Test Set.
- E5515CU Option 504. This consists of a kit that includes the rear panel with a Digital Bus connector and a circuit board for switching the baseband signal path between faded and non-faded applications.
- E5515CU Option 003 Flexible Radio Link.
- E6702B cdma2000 Lab Application, E6706A 1xEV-DO Lab Application, or E6703C W-CDMA Lab Application.

Product Description

NOTE The E5515CU Option 504 is a field installable upgrade kit. Installation can be performed at the customer's site.

PC hardware and software

- N5101A Baseband Studio PCI card.
- N5115A Baseband Studio for Fading software.
 - N5115A Baseband Studio for Fading Option 160 (one fading channel for up to 17 MHz RFBW).
 - N5115A Baseband Studio for Fading Option 168 (adds AWGN to a fading channel).
 - N5115A Baseband Studio for Fading Option 172 (adds E5515C connectivity).
 - Agilent E2094M IO Libraries Version M.01.02 or later (included with N5515A).
 - .Net Framework 1.1 (included with N5515A).
- GPIB interface hardware and software drivers (Agilent 82357A USB/GPIB Interface recommended).
- License file (must be saved to C:\Agilent\Program Files\Baseband Studio\LicenseFiles).

NOTE Minimum PC requirements (processor, memory, etc.) are specified in the N5101A Baseband Studio PCI Card Installation Guide. See "Related Documentation" on page 83.

Cables

- Digital Bus cable (included with the N5101A).
- GP-IB cable (Agilent 82357A USB/GPIB Interface recommended).
- RF cable.

How is a Faded Signal Generated?

The Baseband Studio for Fading software running on the PC generates fading patterns and AWGN on the forward channel. RF power levels, including AWGN, are controlled by this software.

The fader software is designed to control the following test set functions via GPIB:

- Selecting the test set's Open Loop ALC (Automatic Level Control) mode.

- Configuring the baseband signal path switches to route digital I/Q to and from the Digital Bus.
- Setting up a fading headroom value (see “Impairments Backoff” on page 67).
- Compensation for time delay through the external (Digital Bus) path.
- Setting the test set’s AWGN generator to OFF.

NOTE When the test set is configured to generate a faded signal, the test set’s internal AWGN generator is automatically turned off to allow the AWGN to be added by the external fading software. The resulting RF signal from the test set will have fading applied to the forward or downlink channel only, with no fading applied to AWGN.

Test sets equipped with option 504 have the capability to re-route the digital baseband signal. Using GPIB commands and front panel controls, the test set can be configured to route the baseband IQ digital data to the rear panel Digital Bus interface, where it is converted to a format compatible with the PCI card on the PC (see “The Digital Bus Connection” on page 73).

The Baseband Studio for Fading software running on the PC mathematically integrates fading patterns with the baseband signal depending on the user-requested fading pattern and AWGN setting. The faded digital IQ data is sent back to the test set on the Digital Bus, where it is converted back to the data format used by the test set.

The digitally faded data is then sent to the test set’s analog IQ circuit and provides the forward channel modulation source for the RF output.

The fading software controls the test set’s internal baseband signal path switching when the fader is turned on. See Figure 3. on page 10

Product Description

Figure 3. Baseband Signal Transmitter Path

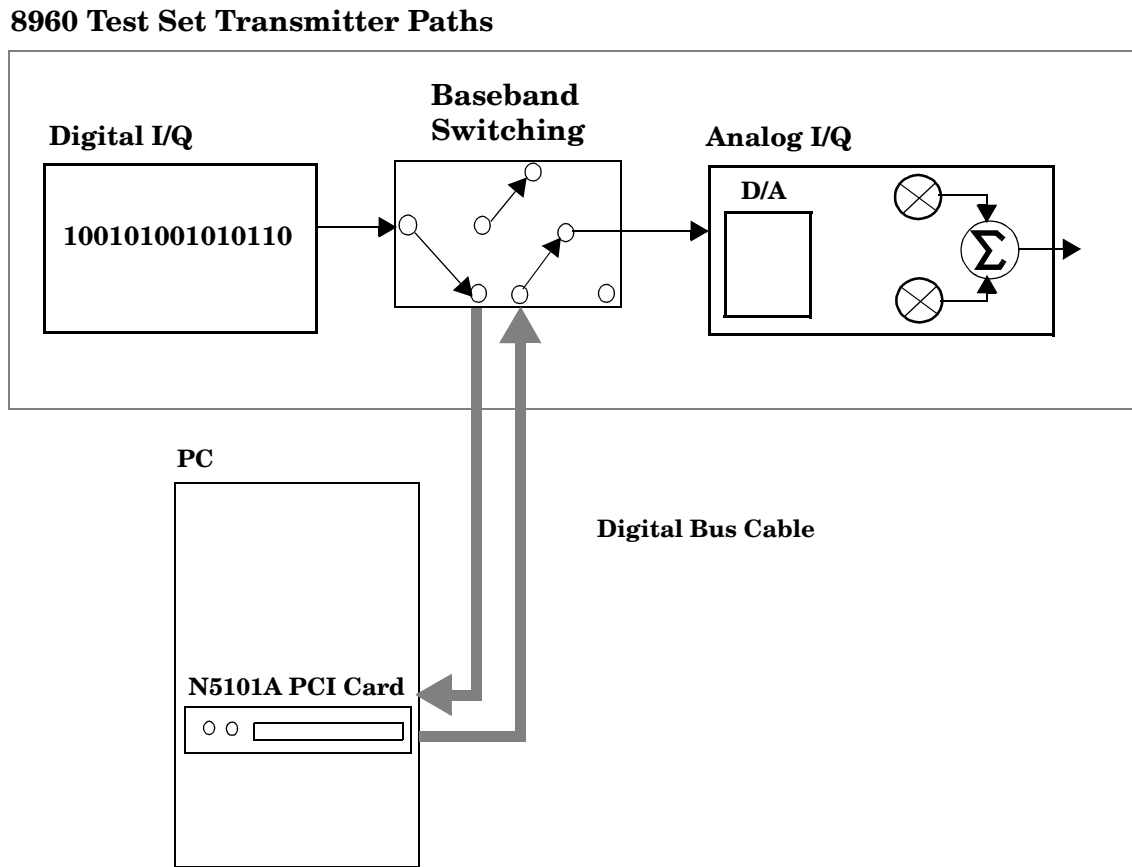

What Fading Patterns are Available?

Fading patterns include:

- Rayleigh
- Flat
- Doppler
- Suzuki

Standard test patterns are available in the software and can be modified if necessary. For example, the cdma2000 mobile test choices include:

- Case 1
- Case 2
- Case 3
- Case 4
- Case 5

- Case 6

The 1xEV-DO access terminal test choices include:

- Case 1
- Case 2
- Case 3
- Case 4
- Case 5

The W-CDMA mobile test choices include:

- Case 1
- Case 2
- Case 3
- Case 4
- Case 5
- Case 6
- Birth-Death
- Moving Propagation

Descriptions of standard test patterns are provided in the fading software's online help.

Operating Overview

This section provides the fundamental operating information for the E5515C Fading Solution (fader).

For reference information about the N5115A Baseband Studio for Fading (fading software) controls, refer to the online help.

For reference information about the E5515C controls, refer to the online reference guides. To access these guides, go to www.agilent.com/find/E6702B (cdma2000 Lab Application), www.agilent.com/find/E6706A (1xEV-DO Lab Application) or www.agilent.com/find/E6703C (W-CDMA Lab Application).

Configuring the Fader System

Before you configure the fader system, the PC must have the N5101A PCI card, software drivers, and fading software license file installed in the PC. See “Hardware and Software Checklist” on page 7.

(For hardware and software installation instructions, refer to the N5101A Baseband Studio PCI Card Installation Guide shipped with the PCI card.)

In the fader software Welcome screen there is a System Configuration dialog that is used to setup and test the GPIB and the PCI card interfaces. This dialog gives you access to the System Configuration Add Wizard (wizard), which will setup and verify communication with the fader hardware in your system.

IMPORTANT Make sure the test set’s power is on and a lab application (cdma2000, 1xEV-DO, or W-CDMA) is selected before you configure the fader system.

1. Start the Baseband Studio for Fading software. From the Start, Programs menu, select:

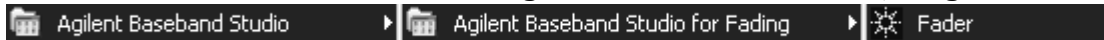

When you start up the fading software, a Welcome screen appears, which allows you access to the System Configuration dialog.

NOTE If the Welcome screen does not appear, simply click the Tools menu and select System Configuration to access the System Configuration Add Wizard. Skip ahead to the section titled “Using the System Configuration Add Wizard” on page 15.

2. Select New Hardware Configuration from the Baseband Studio software Welcome screen:

Operating Overview

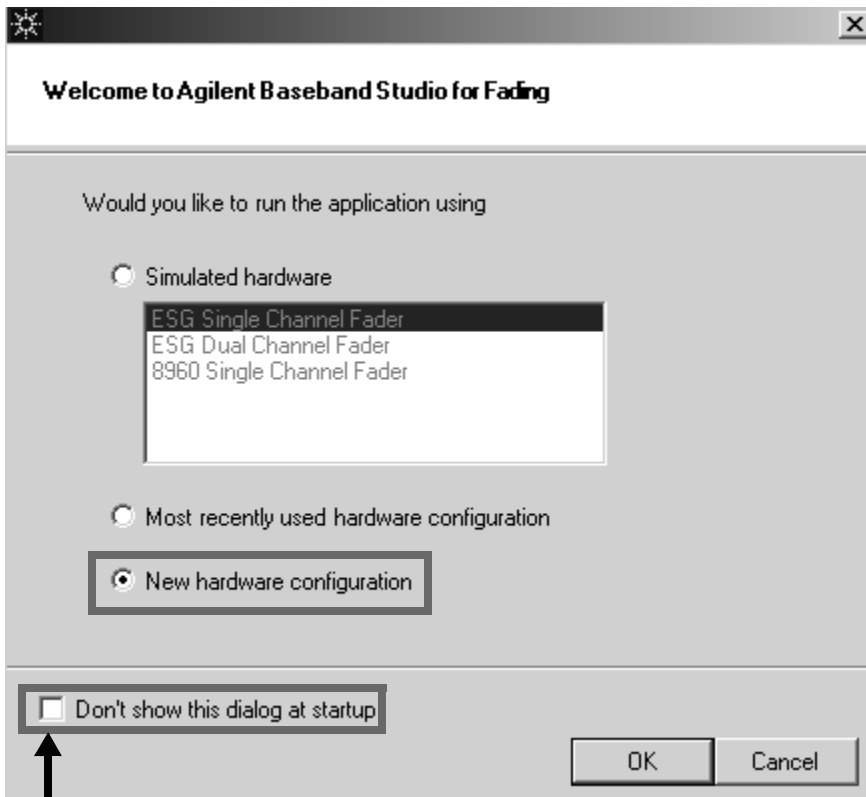

Selecting this checkbox is optional

- Unless you plan to identify a new hardware configuration next time you start up the fading software, it is recommended that you select the “Don’t show this dialog at startup” checkbox. The System Configuration dialog can always be accessed from the Tools menu.
- Click OK.

Using the System Configuration Add Wizard

1. If a valid system configuration has already been specified and is listed in the System Configuration dialog box, skip ahead to “Selecting and Testing the System Configuration” on page 21. Otherwise, click on the Add button to run the System Configuration Add Wizard.

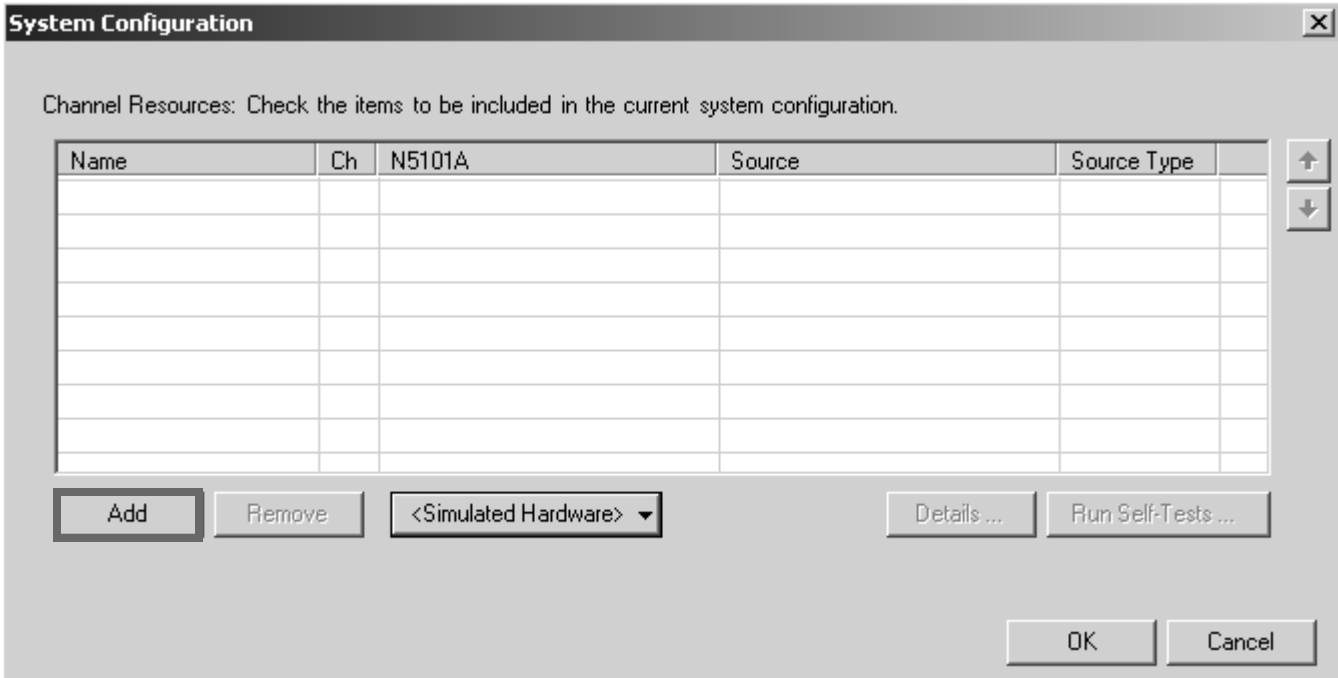

2. Select N5101A PCI card + 8960 Mainframe.

Operating Overview

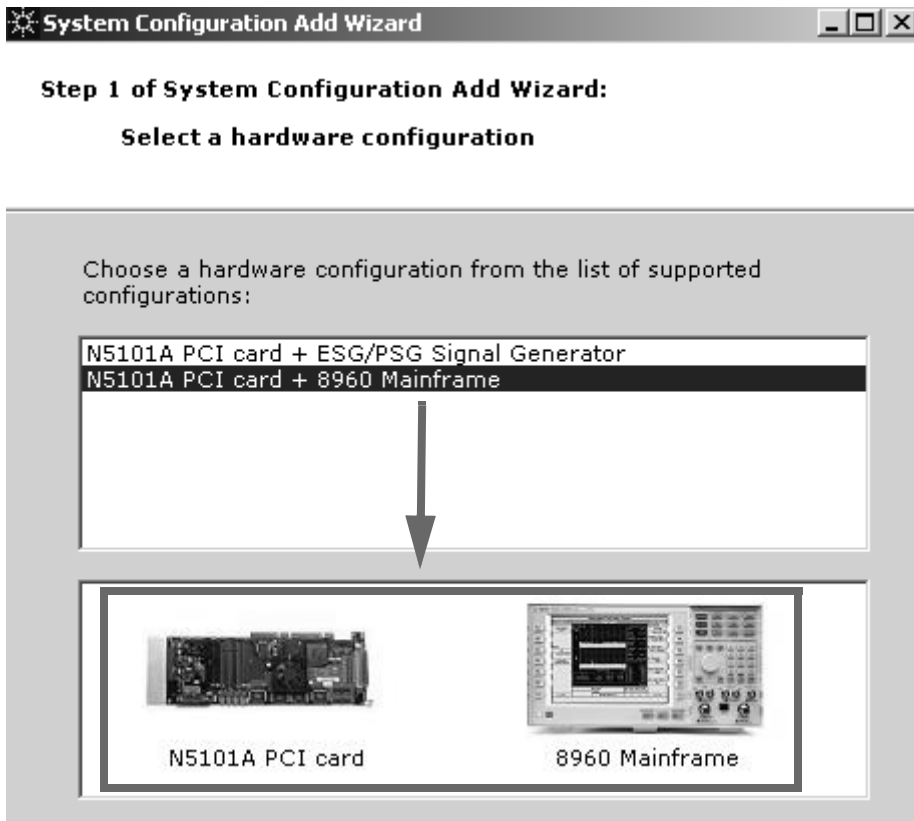

3. Click Next >.

4. A list of the N5101A PCI cards that have been detected on your PC is displayed. Select a PCI card.



NOTE If you have more than one card installed in your PC, you can click the Toggle LED button to toggle a yellow LED visible from the PC's rear panel. This will verify that the digital bus cable is connected to the PCI card you are selecting.

5. Click Next >.

Operating Overview

6. Select GPIB in the “Enter a new 8960 Mainframe” dialog.

NOTE The 8960 does not support LAN instrument control. The PC must be configured with GPIB hardware and the required drivers. For easy connectivity with good performance, Agilent Technologies recommends the Agilent 82357A USB/GPIB Interface. See www.agilent.com/find/gpib.

System Configuration Add Wizard

Step 3 of System Configuration Add Wizard:
Select an 8960 Mainframe

Enter the 8960 Mainframe connection information below:

Enter a new 8960 Mainframe:

GPIB (selected in dropdown)

Board Index: 0 (selected in dropdown)

Primary Address: 14 (selected in dropdown)

Secondary Address: 0 (selected in dropdown)

Choose a 8960 Mainframe from the list of configured interfaces in IO Libraries:

Buttons: View Properties, Test I/O Connection, < Back, Next >, Cancel

Test Set System Config Screen

System Config Screen	
Configuration Summary	
Instrument Information	
Application:	CDNA 2000 Lab App B
	E6702B B.02.11
Format:	IS-2000/IS-95/ANPS
GPIB Address:	14

7. Configure the GPIB interface between the test set and PC by selecting the Board Index and Primary Address for your GPIB interface:
 - a. Verify the Board Index field matches the GPIB interface name, which is assigned when you run the GPIB driver configuration.

TIP If you are not sure you have the right Board Index selected you can click the Test I/O Connection button. If the test connection fails, try another Board Index or run your GPIB driver configuration program to determine the GPIB interface name. See “GPIB Configuration” on page 80

- b. Verify the test set’s GPIB address matches the Primary Address field. You can find out the test set’s GPIB address by pressing the **SYSTEM CONFIG** key.

8. Click Next >.
9. In step 4 of the System Configuration Add Wizard, the software automatically runs a test of the GPIB I/O connection and reports the result.



10. Click Next > if the “8960 Mainframe connected” message appears. Click < Back if the connection fails, and correct the GPIB configuration.
11. Enter a name for the system you have just set up. (Any combination of characters and numbers is permissible).

Operating Overview



12. Click Finish to return to the System Configuration utility.

Selecting and Testing the System Configuration

1. Check the box next to your system configuration. Selecting this checkbox will automatically assign the system configuration to Ch (channel) 1.

The example below shows the E5515C (referred to as the Source Type) configured with a GPIB primary address of 14 and an N5101A PCI card assigned to fader channel 1.

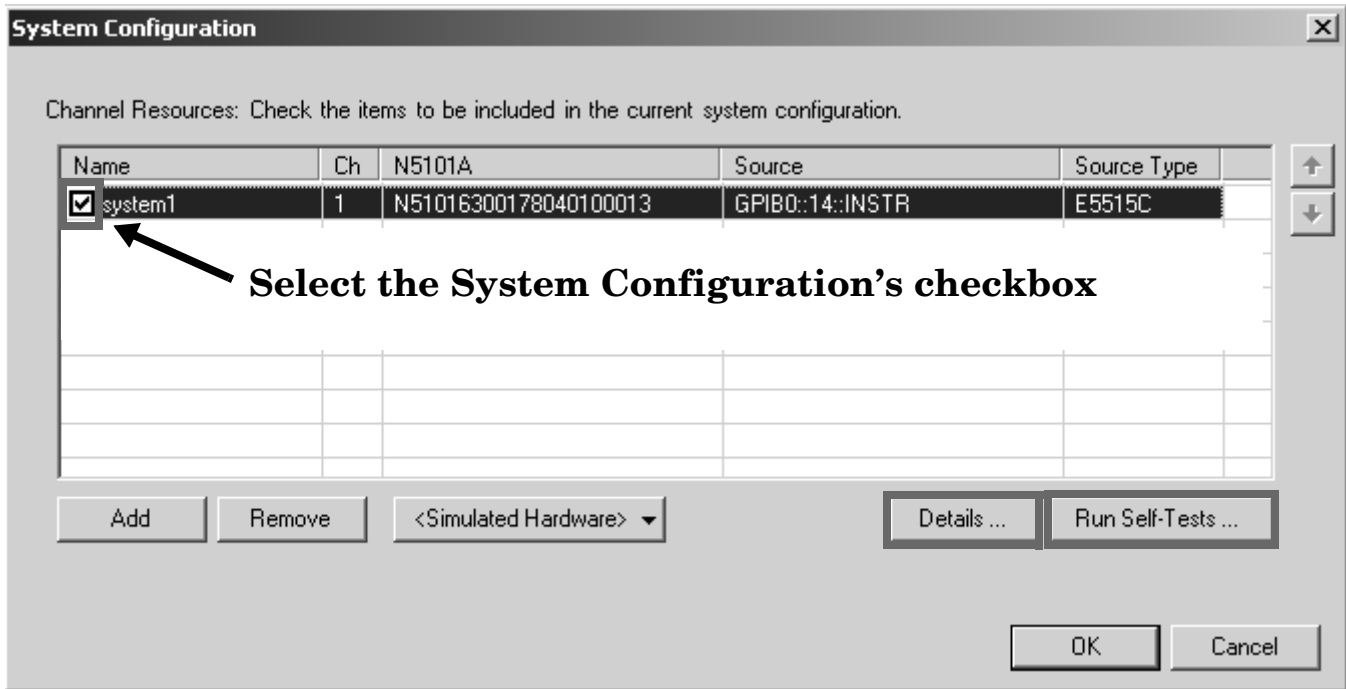

NOTE Other Baseband Studio products have the capability for 2-channel fading. Configurations that use the test set as a signal source are currently limited to single channel operation.

2. You can click the Run Self-Tests button to check system connectivity.
3. You can also click the Details button to display the View System Details window.

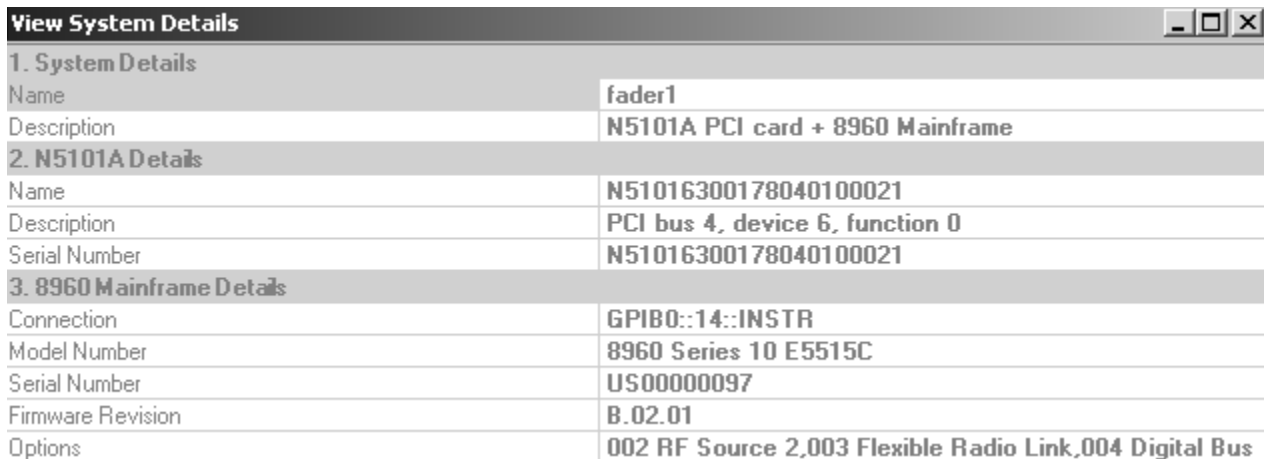

4. Click OK.

Operating Overview

The system you have just configured now appears in the Channel Resource box.



If the Channel Resource box displays (None), you must go into the System Configuration dialog and select the checkbox next to one of the items displayed in the Channel Resources list.

Faded Test Example Procedures

The following examples detail how to perform faded tests on wireless devices as defined by the 3GPP and 3GPP2 test specifications, using the E5515C Fading Solution.

- “Testing a cdma2000 Mobile Station with a Faded Channel” on page 25
- “Testing a W-CDMA UE with a Faded Channel” on page 38
- “Testing an 1xEV-DO Access Terminal with a Faded Channel” on page 50

Testing a cdma2000 Mobile Station with a Faded Channel

This procedure outlines the steps required to perform test 3.4.2 Demodulation of Forward Fundamental Channel in Multipath Fading Channel, as outlined in test standard 3GPP2 C.S0011 C.

3.4.2 Demodulation of Forward Fundamental Channel in Multipath Fading Channel

3.4.2 Demodulation of Forward Fundamental Channel in Multipath Fading Channel
 This test shall be performed on the Forward Fundamental Channel with Radio Configuration 1 or 2, if the Forward Fundamental Channel with Radio Configuration 1 or 2 is supported by the mobile station.

3.4.2.1 Definition

The performance of the demodulation of Forward Traffic Channel in multipath fading channel is determined by the frame error rate (FER) or the error rate in each frame category. The FER is calculated for each individual data rate. The following table summarizes the fading tests to be performed:

Case	Radio Configuration	Channel Simulator Configuration Number
1	1	1 (8 km/h, 2 paths)
2	1	3 (30 km/h, 1 path)
3	1	4 (100 km/h, 3 paths)
4	2	1 (8 km/h, 2 paths)
5	2	3 (30 km/h, 1 path)
6	2	4 (100 km/h, 3 paths)

Cases 1 and 4 test the demodulation performance for the 8 km/h, two-path case by checking the full rate FER. Cases 2 and 5 test the demodulation performance for the 30 km/h, single-path case by checking the FER at all four possible data rates. Cases 3 and 6 test the demodulation performance and the rate determination for the 100 km/h, three-path case by checking the FER and the error rate in each frame category.

Tip:

This table gives the fading profiles for each of six test Cases.

Each test Case in this table defines a Radio Configuration/Channel Simulator Configuration pair.

The Channel Simulator Configuration Number, not the test case, defines the fading profile used for each test case.

Faded Test Example Procedures

3.4.2.2 Method of Measurement



To perform step 1 of section 3.4.2.2, connect and configure the test set and fading software as described in “Operating Overview” on page 12. Then connect the mobile station to the test set’s front panel **RF IN/OUT** port (or the **RF OUT ONLY** port, see “Output Power” on page 75).

Before beginning testing, be sure that any necessary calibrations have been performed. See “Calibration” on page 70.

1. Connect the base station and an AWGN generator to the mobile station antenna connector as shown in Figure 6.5.1-1.
2. For each band class that the mobile station supports, configure the mobile station to operate in that band class and perform steps 3 through 5.
3. If the mobile station supports demodulation of Radio Configurations 1 or 2, set up a call using Fundamental Channel Test Mode 1 or 2 (see 1.3).
4. Set the test parameters for each test as specified in Tables A.2.2.1-1 through A.2.2.1-9.
5. Count, at the base station, the number of frames transmitted and the number of good frames received at the mobile station. For Cases 3 and 6, count, at the base station, the number of frames received in each category at the mobile station.

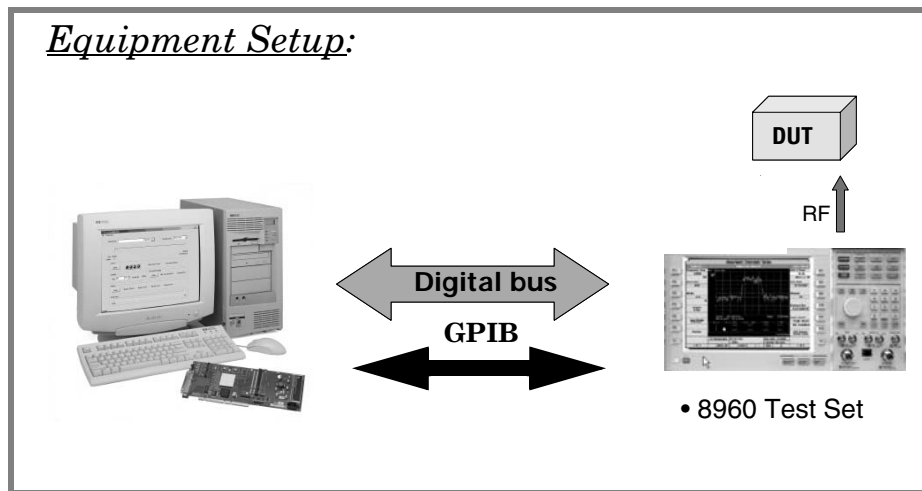
Equipment Setup:



To perform steps 2 through 5 from section 3.4.2.2 follow the instructions in the  and  boxes that follow.

- 18 1. Connect the base station and an AWGN generator to the mobile station antenna
19 connector as shown in Figure 6.5.1-1.
- 20 2. For each band class that the mobile station supports, configure the mobile station
21 to operate in that band class and perform steps 3 through 5.
- 22 3. If the mobile station supports demodulation of Radio Configurations 1 or 2, set up a
23 call using Fundamental Channel Test Mode 1 or 2 (see 1.3).
- 24 4. Set the test parameters for each test as specified in Tables A.2.2.1-1 through
25 A.2.2.1-9.
- 26 5. Count, at the base station, the number of frames transmitted and the number of
27 good frames received at the mobile station. For Cases 3 and 5, count, at the base
28 station, the number of frames received in each category at the mobile station.

 *On the Test Set:*

No operation required.

 *On the PC:*

No operation required.

Faded Test Example Procedures

1. Connect the base station and an AWGN generator to the mobile station antenna connector as shown in Figure 6.5.1-1.
2. For each band class that the mobile station supports, configure the mobile station to operate in that band class and perform steps 3 through 5.
3. If the mobile station supports demodulation of Radio Configurations 1 or 2, set up a call using Fundamental Channel Test Mode 1 or 2 (see 1.3).
4. Set the test parameters for each test as specified in Tables A.2.2.1-1 through A.2.2.1-9.
5. Count, at the base station, the number of frames transmitted and the number of good frames received at the mobile station. For Cases 3 and 6, count, at the base station, the number of frames received in each category at the mobile station.

On the Test Set:

1. Set up Cell Parameters (System ID, Network ID). (Press the **CALL SETUP** hardkey, then press the left side **More** key to display the 2 of X menu. Press the **F2** Cell Info, then **F2** Cell Parameters keys).
2. Select Service Option 2 (S02) for Radio Config 1 (Fwd1, Rvs1). (Press the **CALL SETUP** hardkey, then press the **F12** FCH Service Option Setup key to set up the Service Option).

FCH Service Option Setup	Value
Service Option for Fwd1, Rvs1	S02 (Loopback) ②
Service Option for Fwd2, Rvs2	S09 (Loopback)
Service Option for Fwd3, Rvs3	S02 (Loopback)
Service Option for Fwd4, Rvs4	S055 (Loopback)
Service Option for Fwd5, Rvs5	S055 (Loopback)

3. Set up the call to use Radio Config 1 (Fwd1, Rvs1). (Press the **CALL SETUP** key, then press the **F11** Radio Config key.)

Radio Config
(Fwd1, Rvs1)
(Fwd2, Rvs2)
(Fwd3, Rvs3)
(Fwd4, Rvs3)
(Fwd5, Rvs4)

Radio Config
(Fwd1, Rvs1) ③
S02 (Loopback)

 *On the PC:*

1. Enter the mobile station's Cell Band.
2. Enter the mobile station's RF Channel number.
3. Enter the Cell Power (-55 dBm is usually sufficient power to set up a call).

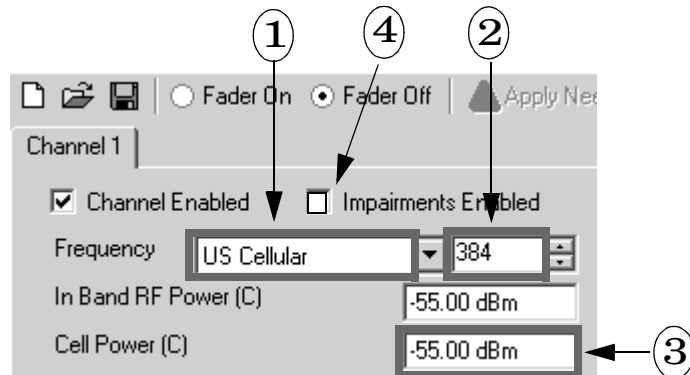

4. Clear the Impairments Enabled checkbox if it is selected. This will disable fading while a call is attempted.
5. Click the Fader On button. This action causes the fading software to download the settings from steps 1-4 to the test set.

Turning the fader on also configures the test set for fading, which disables certain settings and requires that some settings not be changed. See “Critical Fading Solution Settings” on page 65.

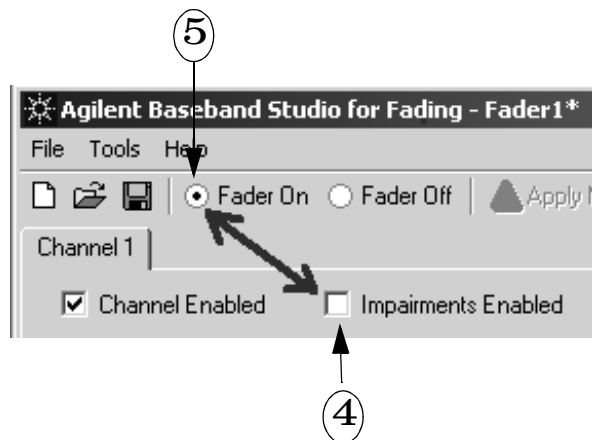

Faded Test Example Procedures

On the Test Set:

1. Turn on the mobile station and verify that the Mobile Station Information screen (press the **Call Setup** key) is updated, indicating that the mobile station has registered.



2. Press the **Originate Call** key.

3. Verify that the call status field indicates that the call is connected.

The image shows a rectangular box with a thin border. Inside the box, the text 'Active Cell' is on the top line and 'Connected' is on the bottom line.

Active Cell
Connected

IMPORTANT While a call is connected, you must not select `Fader Off`, or the call will drop. If you want to enable/disable fading during a call, select/clear the `Impairments Enabled` checkbox, do not select `Fader Off`. Selecting `Fader Off` will cause a momentary loss of the signal from the test set and the call will drop.

1. Connect the base station and an AWGN generator to the mobile station antenna connector as shown in Figure 6.5.1-1.
2. For each band class that the mobile station supports, configure the mobile station to operate in that band class and perform steps 3 through 5.
3. If the mobile station supports demodulation of Radio Configurations 1 or 2, set up a call using Fundamental Channel Test Mode 1 or 2 (see 1.3).
4. Set the test parameters for each test as specified in Tables A.2.2.1-1 through A.2.2.1-9.
5. Count, at the base station, the number of frames transmitted and the number of good frames received at the mobile station. For Cases 3 and 6, count, at the base station, the number of frames received in each category at the mobile station.

Table A.2.2.1-1. Test Parameters for Forward Fundamental Channel Radio Configuration 1 in Fading Channel (Case 1)

Parameter	Units	Test 1	Test 2	Test 3
I_{or}/I_{oc}	dB		8	
$\frac{Pilot E_c}{I_{or}}$	dB		-7	
$\frac{Traffic E_c}{I_{or}}$	dB	(1): -16.1 (2): -16.1 (3): -17.2	(1): -13.5 (2): -13.5 (3): -16.0	(1): -11.5 (2): -11.5 (3): -15.2
I_{oc}	dBm/ 1.23 MHz		-63	
Data Rate	bps	9600		
$\frac{Traffic E_p}{N_t}$	dB	Not Directly Settable		
Channel Simulator Configuration		1		
(1): EC 5 and 11; (2): EC 0, 2, 3, 7, 9, 10 and 12; (3): EC 1, 4, 6 and 8.				

Tip:

To calculate Cell Power (I_{oc}), add the ratio of Cell Power/AWGN (I_{or}/I_{oc}) with AWGN (I_{oc}).

For example, if I_{or}/I_{oc} is 8 dB and I_{oc} is -63 dBm/1.23 MHz, Cell Power is -65+8 = -55 dBm/ 1.23 MHz.

Table 6.4.1.3-1. Standard Channel Simulator Configurations

Parameters		Channel Simulator Configuration					
		1	2	3	4	5	6
Vehicle Speed [km/h]	Band Classes 0, 2, 3, 5, 7, 9, 10, 11 and 12	8	30	30	100	0	3
	Band Classes 1, 4, 6 and 8	8	14	30	100	0	3
Number of Paths		2	2	1	3	2	1
Path 2 Power (Relative to Path 1) [dB]		0	0	N/A	0	0	N/A
Path 3 Power (Relative to Path 1) [dB]		N/A	N/A	N/A	-3	N/A	N/A
Delay from Path 1 to Input [μ s]		0	0	0	0	0	0
Delay from Path 2 to Input [μ s]		2	2	N/A	2	2	N/A
Delay from Path 3 to Input [μ s]		N/A	N/A	N/A	14.5	N/A	N/A

Tip:

Unless you need to modify a standard fading profile (User Defined Path Config), all you need to do is select the correct Channel Simulator Configuration.

Baseband Studio software will set up all of the correct parameters including number of paths, delays, and Doppler shifts.

Faded Test Example Procedures

On the PC:

1. Select the Impairments Enabled checkbox.
2. Enter -55 in the Cell Power field (See Tip above).
3. Select the AWGN Enabled checkbox.
4. Enter -63 dBm in the In Band Noise Power field.

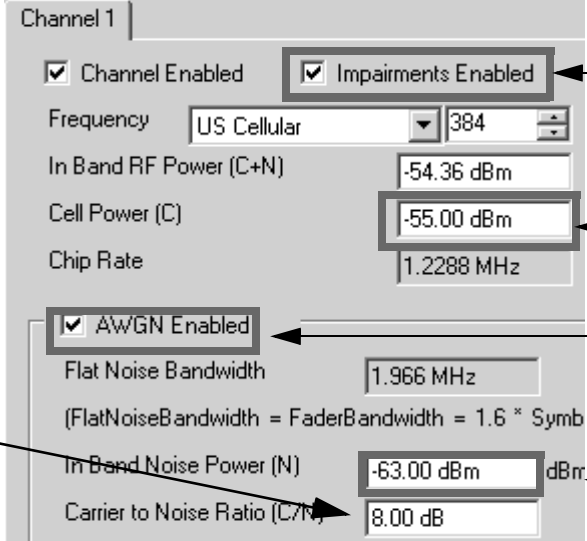

Channel 1

Channel Enabled Impairments Enabled ①

Frequency: US Cellular 384

In Band RF Power (C+N): -54.36 dBm

Cell Power (C): -55.00 dBm ②

Chip Rate: 1.2288 MHz

AWGN Enabled ③

Flat Noise Bandwidth: 1.966 MHz

(FlatNoiseBandwidth = FaderBandwidth = 1.6 * Symb

In Band Noise Power (N): -63.00 dBm dBm ④

Carrier to Noise Ratio (C/N): 8.00 dB

Note that the Carrier to Noise Ratio (C/N) is automatically calculated and matches I_{or}/I_{oc} in the table above.

5. Click the Standard Path Config button and select the cdma2000 Mobile Station fading configuration Case 1.

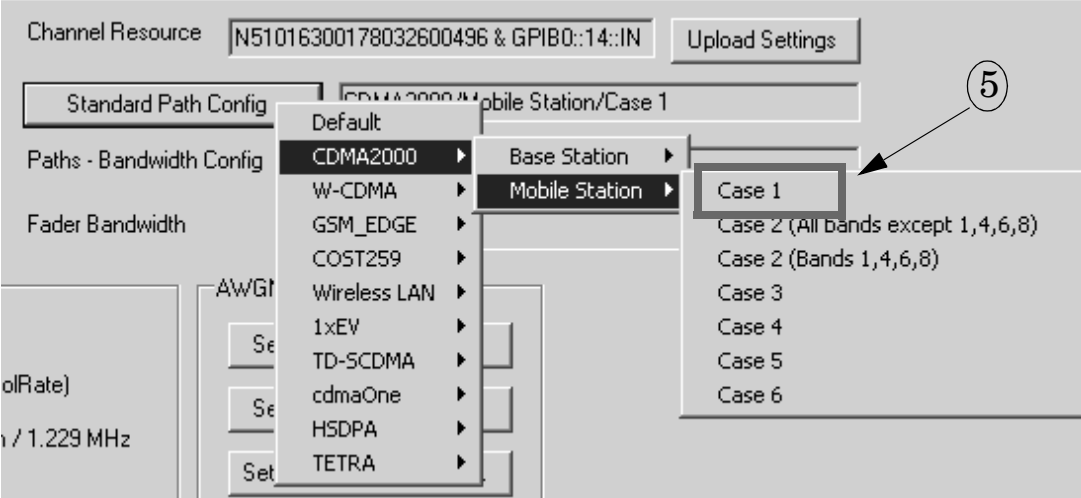

Channel Resource: N51016300178032600496 & GPIB0::14::IN Upload Settings

Standard Path Config: **CDMA2000 Mobile Station/Case 1** ⑤

Paths - Bandwidth Config: CDMA2000 ▶ Base Station ▶ Mobile Station ▶ Case 1

Fader Bandwidth: GSM_EDGE ▶ Case 2 (All bands except 1,4,6,8)

Wireless LAN ▶ Case 2 (Bands 1,4,6,8)

1xEV ▶ Case 3

TD-SCDMA ▶ Case 4

cdmaOne ▶ Case 5

HSDPA ▶ Case 6

TETRA ▶

6. Click Apply Needed



 On the Test Set:



1. Press the **LOCAL** key  to enable front panel operation.
2. Display the Generator Information screen. (Press the **CALL SETUP** key, then press the **More** key on the left side of the display and select **F3** Generator Info key from the 2 of 3 menu).
3. Select the Code Channel Parameters menu. (Press the **F2** Code Channel Parameters key).
4. Set the Cell 1 F-Pilot Level and Cell 1 F-FCH/Traffic Level parameters as shown.

Code Channel Parameters	Value
Cell 1 PN Offset	12
Cell 1 F-Pilot Level	-7.00 dB
Cell 1 F-Sync Level	-16.00 dB
Cell 1 F-Paging Level	-12.00 dB
Cell 1 F-FCH/Traffic Level	-16.10 dB
Cell 1 F-FCH/Traffic Walsh Code	10
Cell 1 F-SCH Level	-15.60 dB

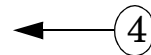

5. Display the Call Setup screen (press the **CALL SETUP** key).
6. Set the Traffic Data Rate field to Full (9600 bps) on the right 2 of 3 menu. (Press the **More** key on the right side of the display and select **F12** Traffic Data Rate from the 2 of 4 menu).

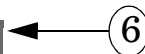
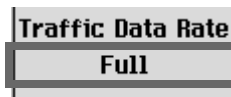

Faded Test Example Procedures

- 18 1. Connect the base station and an AWGN generator to the mobile station antenna
- 19 connector as shown in Figure 6.5.1-1.
- 20 2. For each band class that the mobile station supports, configure the mobile station
- 21 to operate in that band class and perform steps 3 through 5.
- 22 3. If the mobile station supports demodulation of Radio Configurations 1 or 2, set up a
- 23 call using Fundamental Channel Test Mode 1 or 2 (see 1.3).
- 24 4. Set the test parameters for each test as specified in Tables A.2.2.1-1 through
- 25 A.2.2.1-9.
- 26 5. Count, at the base station, the number of frames transmitted and the number of
- 27 good frames received at the mobile station. For Cases 3 and 6, count, at the base
- 28 station, the number of frames received in each category at the mobile station.

On the Test Set:

1. Select the Frame Error Rate measurement.
(Press the **Measurement Selection** key).

Loc	Measurement Selection
	Access to Mobile Power
	Channel Power
	Digital Average Power
	Waveform Quality
	Frame Error Rate
	TX Spurious Emissions

2. (Optional) Select single trigger mode by selecting the Frame Error Rate Setup menu (press the **F1** Frame Error Rate Setup key) and selecting Single in the Trigger Arm field.

Frame Error Rate Setup		Value
Confidence Level		95.00 %
FER Requirement		4.00 %
Maximum Frame C		10000
F-FCH/Traffic Le		-16.10 dB
Trigger Arm	Single	Single
Measurement Tim		Off

If you select single trigger mode, press the **START SINGLE** key to count frame errors.

3.4.2.3 Minimum Standard

Minimum Standard →

2 The actual power measurement uncertainty shall be less than or equal to 0.2 dB (see 6.6.2)
 3 with the minimum test duration meeting the requirements specified in Table 6.6.2-1. Test
 4 durations must be sufficient to meet confidence level requirements.
 5
 6 A minimum confidence level of 95% shall be obtained for the following FER requirements
 7 (see 6.6).
 8
 9 Case 1:
 10 The actual E_b/N_f used in each test shall be within ± 0.5 dB of the value indicated in Tables
 11 A.2.2.1-1 and A.2.2.1-2.
 12
 13 The FER for each test at 9600 bps shall not exceed the piece-wise linear FER curve
 14 specified by the points in Tables A.2.2.2-1 through A.2.2.2-3.

Table 6.6.2-1. Minimum Test Duration Requirements

Band Class	Channel Simulator Configuration							
	1		3		4		6	
	seconds	frames	seconds	frames	seconds	frames	seconds	frames
5 and 11	50	2500	30	1500	3	150	300	15000
0, 2, 3, 7, 9, 10 and 12	30	1500	20	1000	2	100	200	10000
1, 4, 6 and 8	10	500	7	350	2	100	70	3500

Tip:

The Minimum Frame Count ensures that the FER test runs for a sufficient length of time to allow fading statistics to average out (mean power standard deviation must be less than 0.2 dB).

On the Test Set:

1. Select the Frame Error Rate Setup. (Press the **F1** Frame Error Rate Setup key).
2. Enter the Minimum Frame Count.

Frame Error Rate Setup	Value
Confidence Level	95.00 %
FER Requirement	1.00 %
Minimum Frame Count	1500
Maximum Frame Count	10000
F-FCH/Traffic Level	-15.60 dB
Trigger Arm	Continuous
Measurement Timeout	Off

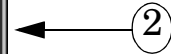

Faded Test Example Procedures

Minimum Standard



- 2 The actual power measurement uncertainty shall be less than or equal to 0.2 dB (see 6.6.2)
- 3 with the minimum test duration meeting the requirements specified in Table 6.6.2-1. Test
- 4 durations must be sufficient to meet confidence level requirements.
- 5 A minimum confidence level of 95% shall be obtained for the following FER requirements
- 6 (see 6.6).
- 7 Case 1:
- 8 The actual E_b/N_t used in each test shall be within ± 0.5 dB of the value indicated in Tables
- 9 A.2.2.1-1 and A.2.2.1-2.
- 10 The FER for each test at 9600 bps shall not exceed the piece-wise linear FER curve
- 11 specified by the points in Tables A.2.2.2-1 through A.2.2.2-3.

Table A.2.2.2-1. Minimum Standards for Fundamental Channel Performance in Fading Channel (Case 1, Tests 1, 2 and 3)

Traffic E_b/N_t [dB]		FER
Band Classes 0, 2, 3, 5, 7, 9, 10, 11 and 12	Band Classes 1, 4, 6 and 8	
6.0	5.4	0.04
6.8	5.7	0.03
9.4	6.9	0.01
11.4	7.7	0.005
11.9	7.9	0.004

 On the Test Set:

1. Select the Frame Error Rate Setup. (Press the **F1** Frame Error Rate Setup softkey).
2. Enter the FER Requirement (4.00% if table specifies 0.04).
3. Press **START SINGLE** and check the Pass/Fail indication.

Frame Error Rate Setup	Value
Confidence Level	95.00 %
FER Requirement	4.00 %
Maximum Frame Count	10000
F-FCH/Traffic Level	-16.10 dB
Trigger Arm	Continuous
Measurement Timeout	Off

Frame Error Rate			
Confidence	FER		
Pass	1.23 %		
Total Frame Errors:	1	Frames Tested:	81
Forward Erasures:	1	Max Frame Count:	10000
Mobile Errors:	0	Eb/Nt:	12.97 dB
Reverse Erasures:	0	FER Requirement:	4.00%

Testing a W-CDMA UE with a Faded Channel

This section outlines the steps required to perform 3GPP TS 34.121 7.3 Demodulation of DCH in Multi-path Fading Propagation Conditions using the E5515C Fading Solution.

7.3 Demodulation of DCH in Multi-path Fading Propagation Conditions

The following excerpt from 3GPP TS 34.121 states the definition and purpose of the tests in 7.3.

7.3 Demodulation of DCH in Multi-path Fading Propagation conditions

7.3.1 Single Link Performance

7.3.1.1 Definition and applicability

The receive characteristics of the Dedicated Channel (DCH) in different multi-path fading environments are determined by the Block Error Ratio (BLER) values. BLER is measured for the each of the individual data rate specified for the DPCH. DCH is mapped into in Dedicated Physical Channel (DPCH).

The UE shall be tested only according to the data rate, supported. The data-rate-corresponding requirements shall apply to the UE.

7.3.1.3 Test purpose

To verify the ability of the receiver to receive a predefined test signal, representing a multi-path fading propagation channel for the wanted and for the co-channel signals from serving and adjacent cells, with a BLER not exceeding a specified value.

The subsequent sections of 7.3 testing are shown in the following pages, followed by instructions for performing the test steps using the fading software (on the PC) and the test set's front panel.

To perform step 1 of section 7.3.1.4.1, connect and configure the test set and fading software as described in “Operating Overview” on page 12. Then connect the UE (mobile phone or other wireless device) to the test set’s front panel **RF IN/OUT** port (or the **RF OUT ONLY** port, see “Output Power” on page 75).

7.3.1.4 Method of test

7.3.1.4.1 Initial conditions

Test environment: normal; see clauses G.2.1 and G.2.2.

Frequencies to be tested: mid range; see clause G.2.4.

1. Connect the SS, multi-path fading simulator and an AWGN noise source to the UE antenna connector as shown in figure A.10.
2. Set up a call according to the Generic call setup procedure.
3. Set the test parameters for test 1-20 as specified table 7.3.1.11, table 7.3.1.13, table 7.3.1.15, table 7.3.1.17 and table 7.3.1.19.
4. Enter the UE into loopback test mode and start the loopback test.
5. Setup fading simulators as fading condition case 1, case 2, case 3 and case 6, which are described in table D.2.2.1.

7.3.1.4.2 Procedures

1. Measure BLER of DCH.

Before beginning testing, be sure that any necessary calibrations have been performed. See “Calibration” on page 70.

Faded Test Example Procedures

To perform steps 2 through 5 from section 7.3.1.4.1 follow the instructions in the  and  boxes that follow.

7.3.1.4 Method of test

7.3.1.4.1 Initial conditions

Test environment: normal; see clauses G.2.1 and G.2.2.

Frequencies to be tested: mid range; see clause G.2.4.

1. Connect the SS, multi-path fading simulator and an AWGN noise source to the UE antenna connector as shown in figure A.10.
2. Set up a call according to the Generic call setup procedure.
3. Set the test parameters for test 1-20 as specified table 7.3.1.11, table 7.3.1.13, table 7.3.1.15, table 7.3.1.17 and table 7.3.1.19.
4. Enter the UE into loopback test mode and start the loopback test.
5. Setup fading simulators as fading condition case 1, case 2, case 3 and case 6, which are described in table D.2.2.1.

7.3.1.4.2 Procedures

1. Measure BLER of DCH.

7.3.1.5 Test requirements

For the parameters specified in tables 7.3.1.11, 7.3.1.13, 7.3.1.15, 7.3.1.17 and 7.3.1.19 the average downlink $\frac{DPCH_E}{I_s}$ power ratio shall be below the specified value for the BLER shown in tables 7.3.1.12, 7.3.1.14, 7.3.1.16, 7.3.1.18 and 7.3.1.20. These requirements are applicable for TFCS size 16.

Table 7.3.1.11: DCH parameters in multi-path fading propagation conditions (Case 1)

Parameter	Test 1	Test 2	Test 3	Test 4	Unit
Phase reference	P-CPICH				
\hat{I}_{or}/I_{oc}	9,6				dB
I_{oc}	-60				dBm / 3,84 MHz
Information Data rate	12,2	64	144	384	kbps

On the Test Set:

1. Set the Call Control and Call Parameters as required for your UE to be able to camp to the test set (press the **CALL SETUP** hardkey, then press the left and right **More** keys to move through the various menus).

Do not power the UE on at this time.

 *On the PC:*

1. Clear the `Impairments Enabled` checkbox if it is selected. This will disable fading while a call is attempted.
2. Click the `Fader On` button (it may take a few seconds for this action to complete).

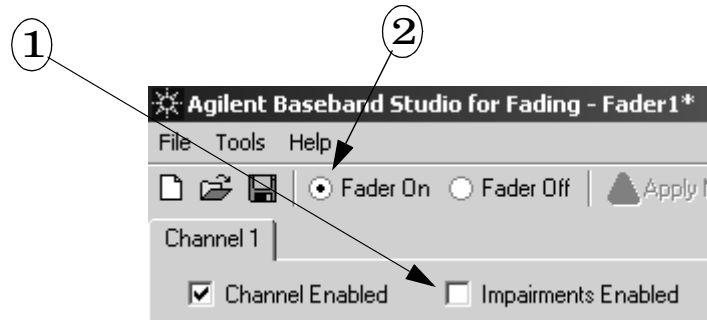

NOTE: Turning the fader on configures the test set for fading, which disables certain test set settings and requires that some settings not be changed. See “Critical Fading Solution Settings” on page 65.

Faded Test Example Procedures

On the Test Set:

1. Set Channel Type (**F8**) to 12.2k RMC (7.3.1 Test 1 requires a 12.2k RMC connection).

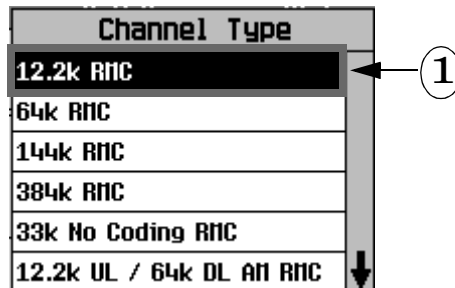

2. To configure the test set properly for the Block Error Ratio measurement required for this test, select RB Test Mode Setup (**F6** on the Call Control 3 of 4 menu). Set Uplink DTCH RMC CRC Presence to Used for Data, and UE Loopback Type to Type 2.

RB Test Mode Settings	Value
RB Test Mode RRC State Setting	CELL_DCH
Uplink DTCH RMC CRC Presence	Used for Data
Uplink Dummy DCCH Data	Off
UE Loopback Type	Type 2

3. Turn on the UE and verify that the UE Information screen (on the Call Setup Screen) is updated, indicating that the UE has camped.
4. Select Originate Call (**F3** on the Call Control 1 of 4 menu).



5. Verify that the call status field indicates that the call is connected.

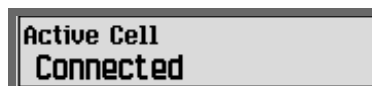

IMPORTANT While a call is connected, you must not select Fader Off, or the call will drop. If you want to enable/disable fading during a call, select/clear the Impairments Enabled checkbox, do not select Fader Off. Selecting Fader Off will cause a momentary loss of the signal from the test set and the call will drop.



To configure the power and noise levels of the faded channel as required for 7.3.1 Test 1, follow the instructions in the  and  boxes on the following pages.

Table 7.3.1.11: DCH parameters in multi-path fading propagation conditions (Case 1)

Parameter	Test 1	Test 2	Test 3	Test 4	Unit
Phase reference		P-CPICH			
\hat{I}_{ov}/I_{oc}		9,6			dB
I_{oc}		-60			dBm / 3,84 MHz
Information Data Rate	12,2	64	144	384	kbps

Table 7.3.1.12: DCH requirements in multi-path fading propagation conditions (Case 1)

Test Number	$\frac{DPCH - E_c}{I_{ov}}$	BLER
1	-14,9 dB	10^{-2}
2	-13,8 dB	10^{-1}
	-9,9 dB	10^{-2}
3	-10,5 dB	10^{-1}
	-6,7 dB	10^{-2}
4	-6,2 dB	10^{-1}
	-2,1 dB	10^{-2}

Faded Test Example Procedures

On the PC:

1. Select the Impairments Enabled checkbox. Impairments Enabled ← ①
2. Select the AWGN Enabled checkbox.
3. Set In Band Noise Power (N) (I_{0c}) to -60.00 dBm.
4. Under AWGN Functions, select Set C/N with constraints.
 - a. Set Carrier to Noise Ratio (C/N) (\hat{I}_{0r}/I_{0c}) to 9.6 dB.
 - b. Select the button next to N, to hold N constant when setting C/N.
 - c. Select OK.

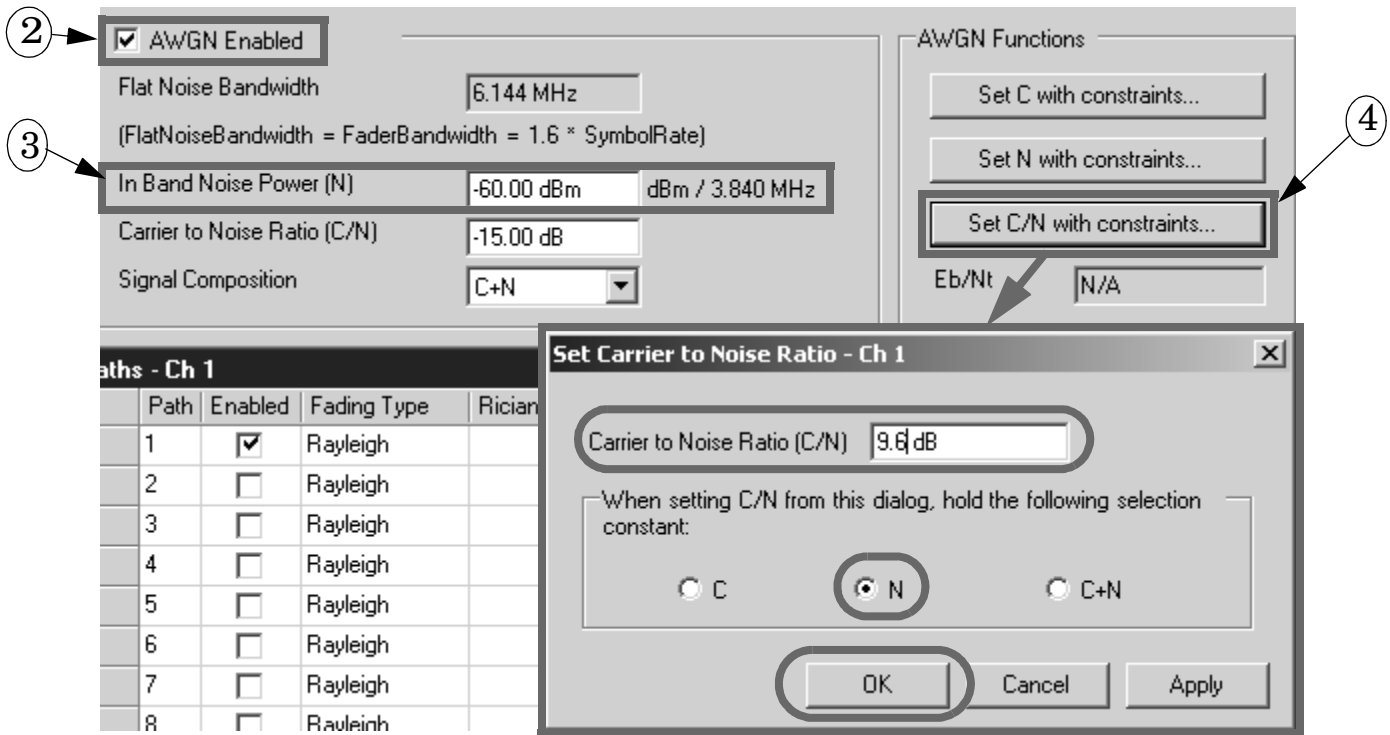

② AWGN Enabled

Flat Noise Bandwidth
(FlatNoiseBandwidth = FaderBandwidth = 1.6 * SymbolRate)

③ In Band Noise Power (N) dBm / 3.840 MHz

Carrier to Noise Ratio (C/N)

Signal Composition

AWGN Functions

Set C with constraints...

Set N with constraints...

④ Set C/N with constraints...

Eb/Nt

Paths - Ch 1				
Path	Enabled	Fading Type	Rician	
1	<input checked="" type="checkbox"/>	Rayleigh		
2	<input type="checkbox"/>	Rayleigh		
3	<input type="checkbox"/>	Rayleigh		
4	<input type="checkbox"/>	Rayleigh		
5	<input type="checkbox"/>	Rayleigh		
6	<input type="checkbox"/>	Rayleigh		
7	<input type="checkbox"/>	Rayleigh		
8	<input type="checkbox"/>	Rayleigh		

Set Carrier to Noise Ratio - Ch 1

Carrier to Noise Ratio (C/N)

When setting C/N from this dialog, hold the following selection constant:

C N C+N

Note that the Cell Power (C) and Carrier to Noise Ratio (C/N) fields are then updated accordingly.

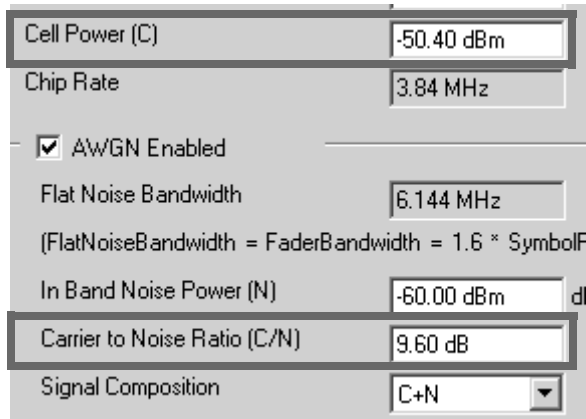

Cell Power (C)

Chip Rate

AWGN Enabled

Flat Noise Bandwidth
(FlatNoiseBandwidth = FaderBandwidth = 1.6 * SymbolRate)

In Band Noise Power (N) dBm

Carrier to Noise Ratio (C/N)

Signal Composition

 On the PC:

5. Click the Standard Path Config button and select the W-CDMA Mobile Station fading configuration Case 1.

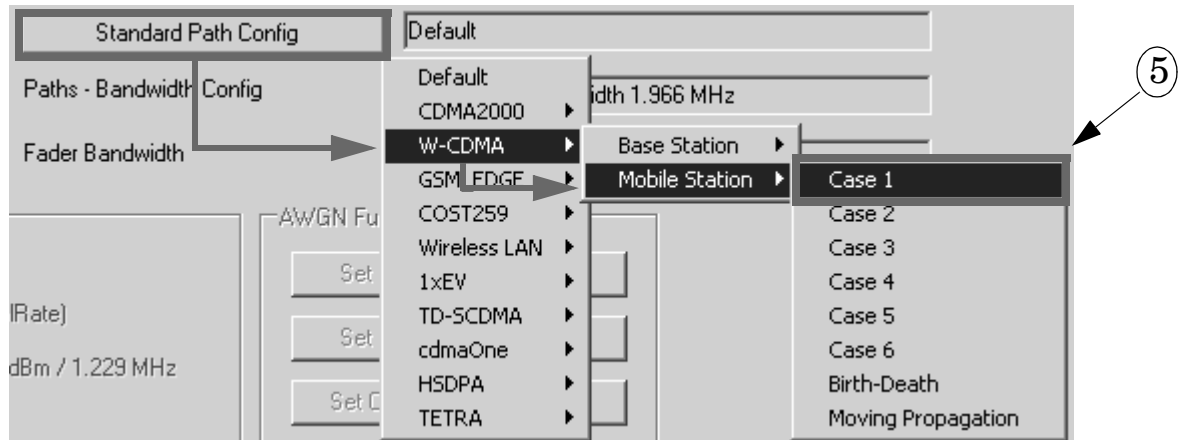

6. Click Apply Needed (it may take a few seconds for this action to complete). Clicking Apply Needed transfers the settings for parameters such as Cell Power and External AWGN to the test set.

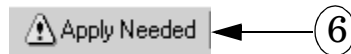

Faded Test Example Procedures

On the Test Set:

1. Display the Generator Information screen. (Press the **CALL SETUP** key, then press the **More** key on the left side of the display and select the **F3** Generator Info key from the 2 of 4 menu).
2. Select Connected DL Channel Levels (**F4**).
3. Set Cell 1 Connected DPCH Level (DPCH_ E_c/I_{or}) to -14.9 dB.

Connected Downlink Channel Levels	Value
Cell 1 Connected CPICH Level	-3.30 dB
Cell 1 Connected P-CCPCH/SCH Level	-5.35 dB
Cell 1 Connected S-CCPCH Level	Off
Cell 1 Connected PICH Level	-8.33 dB
Cell 1 Connected DPCH Level	-14.90 dB
Cell 2 CPICH Level	-3.30 dB
Cell 2 P-CCPCH/SCH Level	-5.35 dB
Cell 2 DPCH Level	-10.30 dB



4. Select Close Menu (**F6**).

To perform step 1 of section 7.3.1.4.2, follow the instructions in the gray box below.

3. Set the test parameters for test 1-20 as specified table 7.3.1.11, table 7.3.1.13, table 7.3.1.15, table 7.3.1.17 and table 7.3.1.19.

4. Enter the UE into loopback test mode and start the loopback test.

5. Setup fading simulators as fading condition case 1, case 2, case 3 and case 6, which are described in table D.2.2.1.

7.3.1.4.2 Procedures

1. Measure BLER of DCH.

On the Test Set:

1. Initiate the Block Error Ratio measurement.

(Press the **Measurement Selection** key, scroll down and select Block Error Ratio.)

Loc	Measurement Selection
	PRACH Transmit On/Off Power
	Phase Discontinuity
	Block Error Ratio
	Dynamic Power Analysis
	PRACH Preamble Analysis

2. Select Block Error Setup (**F1**)

- a. Set Trigger Arm to Single.

- b. Set Number of blocks to test to at least 8200 (34.121 Table F.6.1.6.2 specifies the minimum test time as 164 s for a 3km/h fading profile, which corresponds to 8200 20 ms blocks.)

Block Error Ratio Setup	Value
Number of blocks to test	8200
Trigger Arm	Single
Measurement Timeout	Off
Uplink DTCH RNC CRC Presence	Used for Data
UE Loopback Type	Type 2

3. Press the **START SINGLE** key to start the BLER measurement.

Note: With Number of blocks to test set to 8200, it takes ~2.5 minutes for the BLER results to be displayed.

Faded Test Example Procedures

Compare your measured BLER result with the test requirements of section 7.3.1.5.

7.3.1.5 Test requirements

For the parameters specified in tables 7.3.1.11, 7.3.1.13, 7.3.1.15, 7.3.1.17 and 7.3.1.19 the average downlink $\frac{DPCH_E}{I_{or}}$ power ratio shall be below the specified value for the BLER shown in tables 7.3.1.12, 7.3.1.14, 7.3.1.16, 7.3.1.18 and 7.3.1.20. These requirements are applicable for TFCS size 16.

Table 7.3.1.11: DCH parameters in multi-path fading propagation conditions (Case 1)

Parameter	Test 1	Test 2	Test 3	Test 4	Unit
Phase reference	P-CPICH				
\hat{I}_{or}/I_{oc}	9,6				dB
I_{oc}	-60				dBm / 3,84 MHz
Information Data Rate	12,2	64	144	384	kbps

Table 7.3.1.12: DCH requirements in multi-path fading propagation conditions (Case 1)

Test Number	$\frac{DPCH_E}{I_{or}}$	BLER
1	-14,9 dB	10^{-2}
2	-13,8 dB	10^{-1}
	-9,9 dB	10^{-2}
3	-10,5 dB	10^{-1}

On the Test Set:

1. Verify that the Block Error Ratio result is less than 10^{-2} (1%).

BLER	
Block Error Ratio	
0.23 %	
Block Error Count:	19
Blocks Tested:	8200
Uplink Missing Blocks:	0
8200 / 8200	Single

To perform Tests 2 through 20 in section 7.3.1.4.1, follow the directions in the gray boxes below.

 On the PC:

1. Clear the `Impairments Enabled` checkbox. (It is recommended that you perform call processing operations, such as changing RMCs, without channel impairments, to ensure that the UE is able to receive and properly decode the signaling from the test set).
2. Click `Apply Needed`.

 On the Test Set:

1. Perform a Transport Channel Reconfiguration to the required RMC (Press the **CALL SETUP** key, select `Handoffs (F5)`, then `Transport Chan Reconfig (F2)`. Set `Handoff RB Test Mode RAB`. Select `Execute Handoff (F5)`. Ensure that the call status is still `Connected`.)
2. Set `Cell 1 Connected DPCH Level` as required.

 On the PC:

1. Select the `Impairments Enabled` checkbox.
2. Set the `Carrier to Noise Ratio (C/N)` as needed using the `Set C/N with constraints dialog box`.
3. Select the required `Standard Path Config`.
4. Click `Apply Needed`.

 On the Test Set:

1. Set the `Number of Blocks to Test` as needed.
2. Press the **START SINGLE** key. Wait for BLER results to be displayed.

Testing an 1xEV-DO Access Terminal with a Faded Channel

This section outlines the steps required to perform 3GPP2 C.S0033 3.1.1.2.2 Demodulation of Forward Traffic Channel in Multipath Fading Channel using the E5515C Fading Solution.

3.1.1.2.2 Demodulation of Forward Traffic Channel in Multipath Fading Channel

The following excerpt from 3GPP2 C.S0033 states the definition of the tests in 3.1.1.2.2 and the standard channel simulator configurations as defined in 11.4.1.1.

3.1.1.2.2 Demodulation of Forward Traffic Channel in Multipath Fading Channel

3.1.1.2.2.1 Definition

The performance of the demodulation of Forward Traffic Channel in multipath fading channel is determined by the packet error rate (PER). The PER is calculated for 38.4 kbps and 76.8 kbps data rates. The following table summarizes the fading tests to be performed:

Case	Channel Simulator ¹⁰ Configuration Number
1	1
2	2
3	3
4	4

Tip:

Each test Case of 3.1.1.2.2 requires a standard Channel Simulator Configuration which defines the fading profile. For details, see the excerpted table on next page.

Case 1 tests the demodulation performance for the 8 km/h, two-path case by checking the PER at the 38.4 kbps and 76.8 kbps data rates.

Case 2 tests the demodulation performance for the 3 km/h, single-path case by checking the PER at the 38.4 kbps and 76.8 kbps data rates

Case 3 tests the demodulation performance for the 30 km/h, single-path case by checking the PER at the 38.4 kbps and 76.8 kbps data rates.



Case 4 tests the demodulation performance for the 100 km/h, three-path case by checking the PER at the 38.4 kbps and 76.8 kbps data rates.

Refer to 11.4.1.1 for the standard channel simulator configurations.

(see next page)

Standard Channel Simulator Configurations

Parameters		Channel Simulator Configuration				
		1	2	3	4	5
Vehicle Speed [km/h]	Band Classes 0, 2, 3, 7, 9, 10, and 12	8	3	30	100	0
	Band Classes 1, 4, 6, and 8	8	3	30	100	0
	Band Class 5 and 11	15	6	58	192	0
Number of Paths		2	1	1	3	2
Path 2 Power (Relative to Path 1) [dB]		0	N/A	N/A	0	0
Path 3 Power (Relative to Path 1) [dB]		N/A	N/A	N/A	-3	N/A
Delay from Path 1 to Input [μ s]		0	0	0	0	0
Delay from Path 2 to Input [μ s]		2	N/A	N/A	2	2
Delay from Path 3 to Input [μ s]		N/A	N/A	N/A	14.5	N/A

The subsequent sections of 3.1.1.2.2 testing are shown in the following pages, followed by instructions for performing the test steps using the fading software on the PC  and the test set's front panel .

Faded Test Example Procedures

To perform step 1 of section 3.1.1.2.2.2, connect and configure the test set and fading software as described in “Operating Overview” on page 12. Then connect the 1xEV-DO access terminal to the test set’s front panel **RF IN/OUT** port (or the **RF OUT ONLY** port, see “Output Power” on page 75).

3.1.1.2.2.2 Method of Measurement

1. Connect the sector, the channel simulator and an AWGN generator to the access terminal antenna connector as shown in Figure 11.5.1-1.

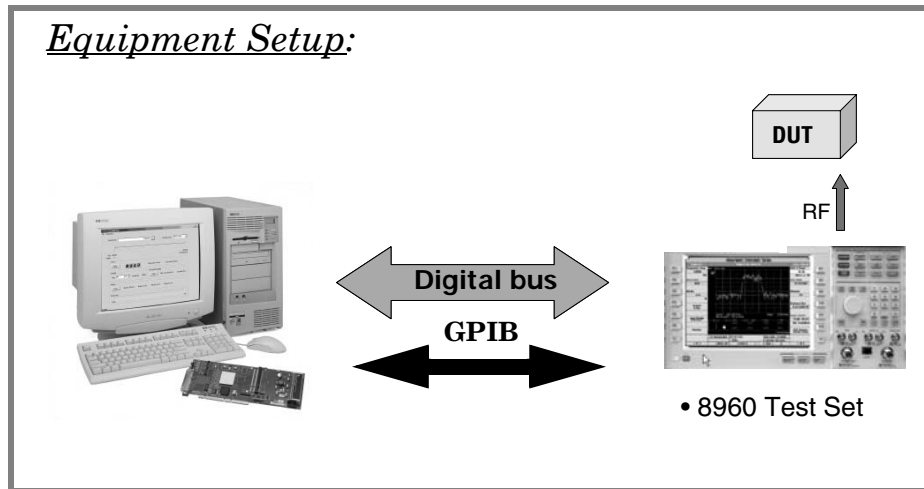

IMPORTANT Before beginning testing, be sure that any necessary calibrations have been performed. See “Calibration” on page 70.

To perform steps 2 and 3 from section 3.1.1.2.2.2, follow the instructions in the  and  boxes that follow.

2. Set the access network equipment's forward packet activity to 100%. Set the access network equipment's Control Channel data rate to 38.4 kbps.

3. Set the *SetManagementSameChannelParameters* attribute fields of the Default Route Update Protocol to the values specified below:

Field	Value (Hex)
PilotDrop	0x1c (-14 dB)



 *On the Test Set:*

1. You do not need to make any setting for Forward packet activity because it is fixed to 100% in the test set.
2. Set the Control Channel Data Rate to 38.4 kbps. (Press the **CALL SETUP** hardkey, then press the left side **More** key to display the 2 of 3 menu. Press the **F2** (Access Network Info), then the **F2** (Cell Parameters) key. Use the knob and DATA ENTRY keys to set the control channel data rate.
3. Set the Pilot Drop (**F5**) to 28. (The pilot drop threshold used by the AT is -0.5 dB times the pilot drop value sent by the test set.)

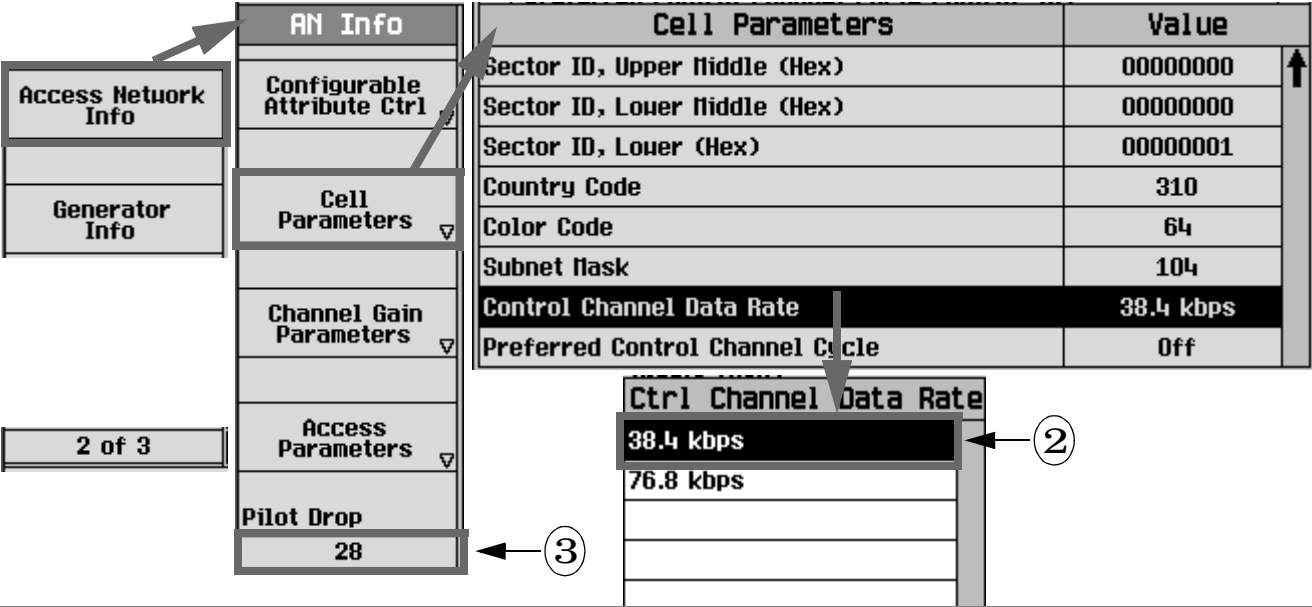
Tip: Do not power the Access Terminal on at this time.



Faded Test Example Procedures

To perform step 4 from section 3.1.1.2.2.2 follow the instructions in the  and  boxes that follow.

4. Set up a Test Application session. Open a connection and configure the Test Application FTAP so that the Forward Traffic Channel rate corresponds to the rate of the test only.
5. Once the connection is established, set the test parameters for Test 1 as specified in Table 3.1.1.2.2.2-1.

On the Test Set:

1. Set the parameters as required for your AT to camp to the test set such as Cell Power, Cell Band, Channel, etc. (Press the **CALL SETUP** hardkey, then set the parameters from Call Parm's and Call Control menus. Press the left and right **More** keys to move through the various menus if required.)
2. Set Test Application Protocol to FTAP. (Select Application Config (**F10**), make sure Session Application Type is Test Application and then set the Test Application Protocol to FTAP).

Application Configuration	Value
Session Application Type	Test Application
Test Application Protocol	FTAP
Limited TAP (AT Firmware Rel 3.1)	Off
AT Directed Packets	50 %
ACK Channel Bit Fixed Mode Attribute	On

Application
FTAP
RTAP

Call Parm's
Cell Power
-55.00
dBm/1.23 MHz
Cell Band
US PCS
Channel
425
Application Config
F10
FTAP Rate
307.2 kbps
(2 Slot, QPSK)
RTAP Rate
9.6 kbps

 On the PC:

1. Enter the AT's Cell Band.
2. Enter the AT's RF Channel number.
3. Enter the Cell Power (-55 dBm is usually sufficient power to set up a call).

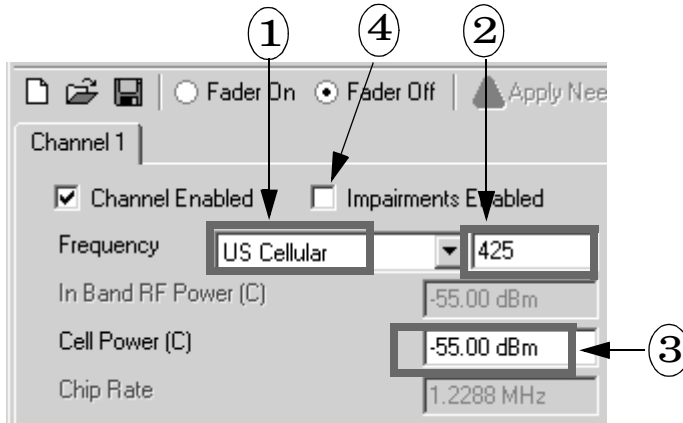

4. Clear the `Impairments Enabled` checkbox if it is selected. This will disable fading while a call is attempted.

5. Click the `Fader On` button (it may take a few seconds for this action to complete). This action causes the fading software to download the settings from steps 1-4 to the test set.

NOTE: Turning the fader on also configures the test set for fading, which disables certain settings and requires that some settings not be changed. See “Critical Fading Solution Settings” on page 65.

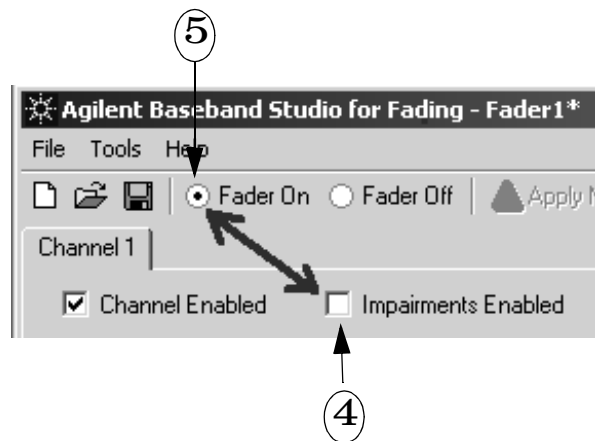

 *On the Test Set:*

1. Turn on the AT and wait for it to open a session. (NOTE: A session can only be originated from the AT. The test set can not open a session.)
2. Verify that the AT Information screen (on the Call Setup Screen) is updated, indicating that the UE has camped. The Active Cell status field indicates that a session is open.

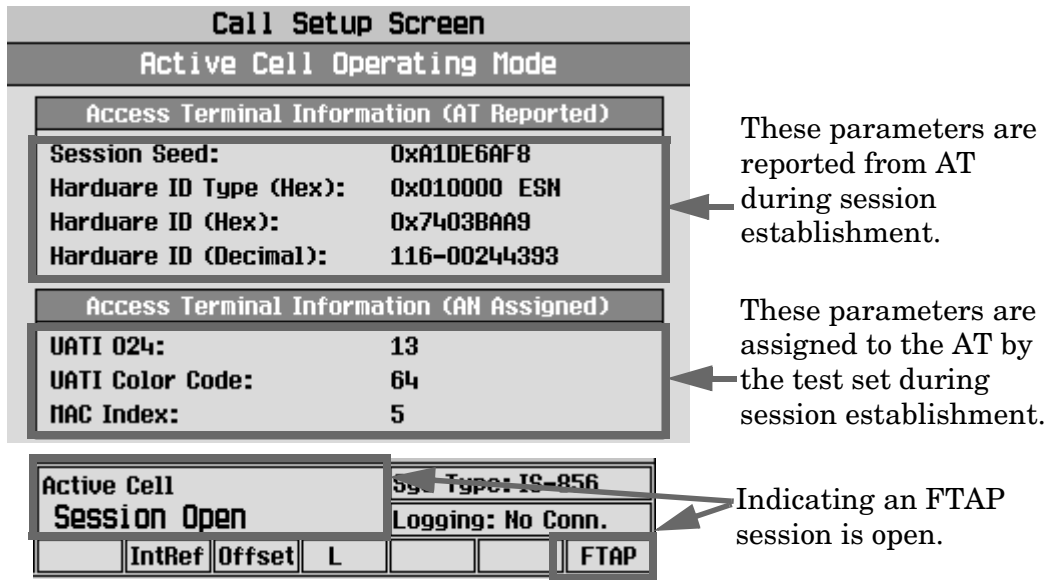

Call Setup Screen
Active Cell Operating Mode

Access Terminal Information (AT Reported)

Session Seed:	0xA1DE6AF8
Hardware ID Type (Hex):	0x010000 ESN
Hardware ID (Hex):	0x7403BAA9
Hardware ID (Decimal):	116-00244393

These parameters are reported from AT during session establishment.

Access Terminal Information (AN Assigned)

UATI 024:	13
UATI Color Code:	64
MAC Index:	5

These parameters are assigned to the AT by the test set during session establishment.

Active Cell
Session Open

IntRef	Offset	L	FTAP
--------	--------	---	------

Indicating an FTAP session is open.

3. Press the **F3** (Start Data Connection on Call Control 1 of 3) to page the AT.



4. Verify that the Active Cell status field indicates that a data connection is established.





Active Cell
Connected

IntRef	Offset	L	FTAP
--------	--------	---	------

Indicating an FTAP data connection is open.

IMPORTANT While a call is connected, you must not select Fader Off, or the call will drop. If you want to enable/disable fading during a call, select/clear the Impairments Enabled checkbox, do not select Fader Off. Selecting Fader Off will cause a momentary loss of the signal from the test set and the call will drop.

To perform step 5 from section 3.1.1.2.2.2 follow the instructions in the  and  boxes that follow. (PCS band is used in this example.)

5. Once the connection is established, set the test parameters for Test 1 as specified in Table 3.1.1.2.2.2-1.

6. From the number of packets transmitted and the number of bad packets received calculate the PER for this test.

Table 3.1.1.2.2.2-1. Test Parameters for FTC Demod in Fading Channel
(Case 1) Part 1 of 2)

Parameter	Units	Test 1	Test 2	Test 3
\hat{I}_{or} / I_{oc}	dB	(1): -6.0 (2): -7.4	(1): -4.2 (2): -5.8	(1): -3.3 (2): -4.6
I_{oc}	dBm/1.23 MHz	(1): -49 (2): -47.6	(1): -50.8 (2): -49.2	(1): -51.7 (2): -50.4
Data Rate	kbps	38.4		
$\frac{\text{Traffic } E_b}{N_t}$	dB	(1): 7.29 (2): 6.02	(1): 8.85 (2): 7.47	(1): 9.59 (2): 8.51
$\frac{\text{Pilot } E_c}{I_o}$	dB	(1): -6.97 (2): -8.13	(1): -5.60 (2): -6.81	(1): -4.97 (2): -5.89
(1): Band Classes 0, 2, 3, 5, 7, 9, 10, 11 and 12		(2): Band Classes 1, 4, 6, and 8		

Note: The Traffic E_b/N_t and Pilot E_c/I_o values are calculated from the parameters set in the table. They are not settable parameter themselves.

Faded Test Example Procedures

On the PC:

1. Select the **Impairments Enabled** checkbox.
2. Select the **AWGN Enabled** checkbox.
3. Set **In Band Noise Power (N) (I_{oc})** to **-47.6 dBm**.
4. Under **AWGN Functions**, select **Set C/N with constraints**.
(Set **Carrier to Noise Ratio (C/N) (\hat{I}_{or}/I_{oc})** to **-7.4 dB**. Select the button next to **N**, to hold **N** constant when setting **C/N**. Select **OK**.)

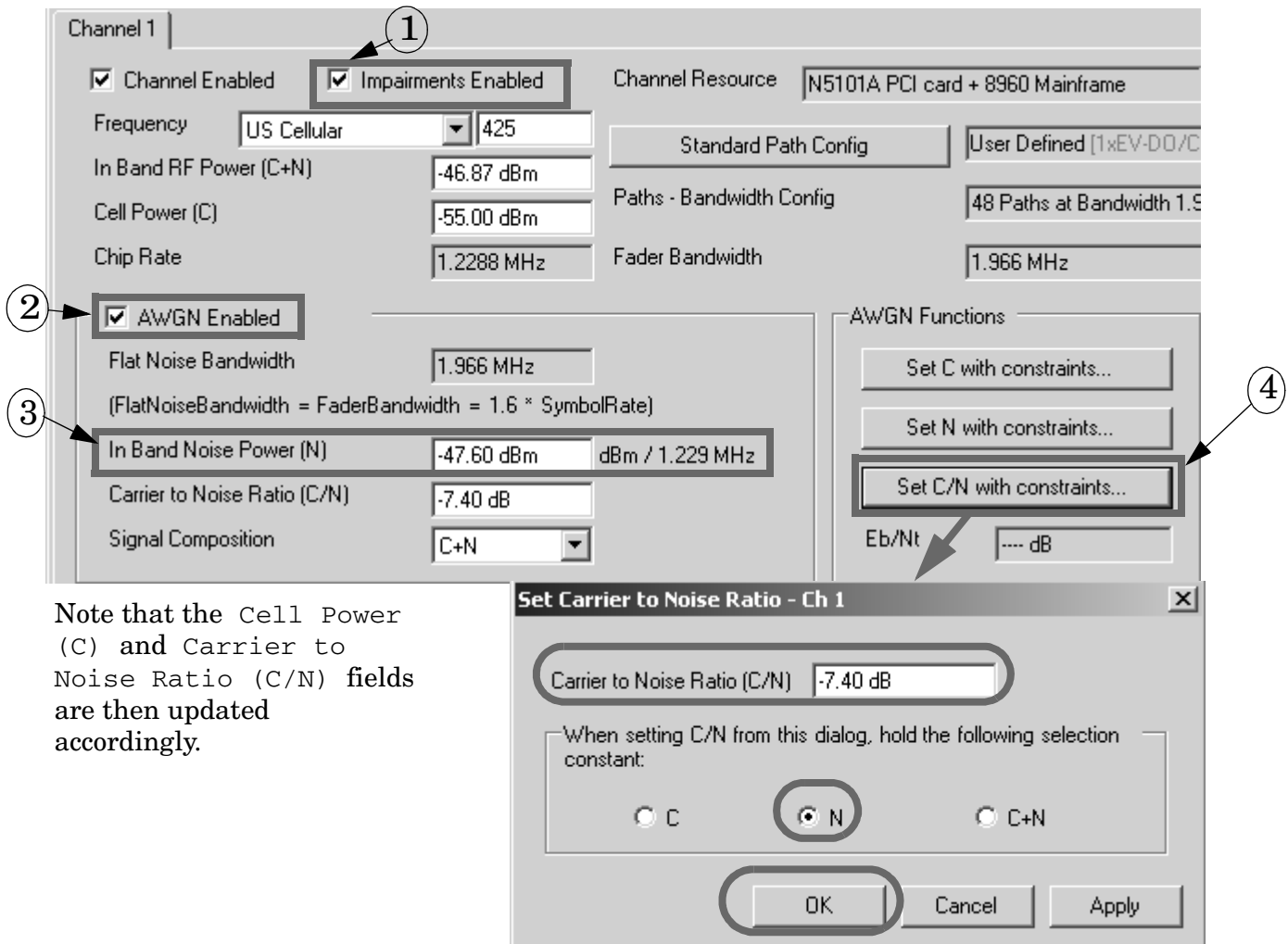

The screenshot shows the 'Channel 1' configuration window with several fields and checkboxes. A circled '1' points to the 'Impairments Enabled' checkbox. A circled '2' points to the 'AWGN Enabled' checkbox. A circled '3' points to the 'In Band Noise Power (N)' field, which is set to '-47.60 dBm dBm / 1.229 MHz'. A circled '4' points to the 'Set C/N with constraints...' button in the 'AWGN Functions' section. Below the main window, a 'Set Carrier to Noise Ratio - Ch 1' dialog box is shown. It has a 'Carrier to Noise Ratio (C/N)' field set to '-7.40 dB'. Below this, there is a section with the text 'When setting C/N from this dialog, hold the following selection constant:' and three radio buttons: 'C', 'N', and 'C+N'. The 'N' radio button is selected. At the bottom of the dialog are 'OK', 'Cancel', and 'Apply' buttons. The 'OK' button is circled.

Note that the **Cell Power (C)** and **Carrier to Noise Ratio (C/N)** fields are then updated accordingly.

 On the PC (continued):

5. Click the Standard Path Config button and select the 1xEV-DO fading configuration Case 1.

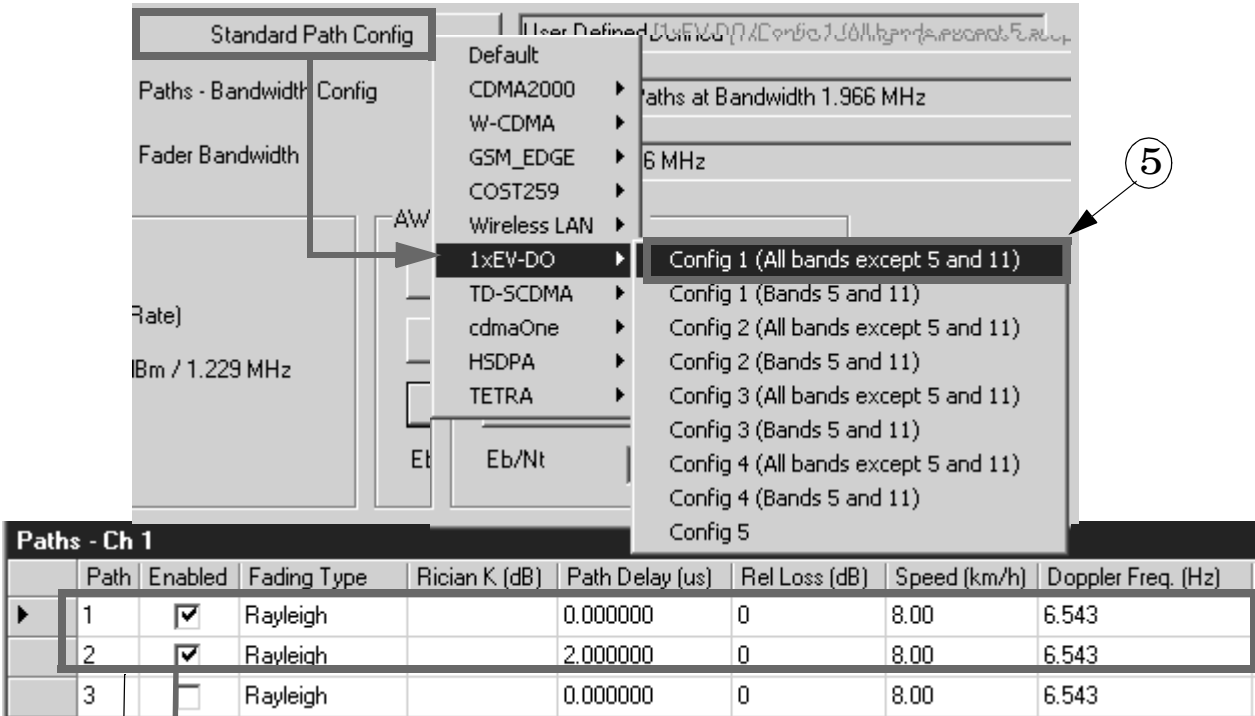

The screenshot shows the 'Standard Path Config' dialog box. The 'Config' dropdown menu is open, showing various fading configurations. '1xEV-DO' is selected, and its sub-menu is open, with 'Config 1 (All bands except 5 and 11)' highlighted. A circled '5' with an arrow points to this selection. Below the dialog is a table titled 'Paths - Ch 1' with the following data:

Path	Enabled	Fading Type	Rician K (dB)	Path Delay (us)	Rel Loss (dB)	Speed (km/h)	Doppler Freq. (Hz)
1	<input checked="" type="checkbox"/>	Rayleigh		0.000000	0	8.00	6.543
2	<input checked="" type="checkbox"/>	Rayleigh		2.000000	0	8.00	6.543
3	<input type="checkbox"/>	Rayleigh		0.000000	0	8.00	6.543

Tips:

Unless you need to modify a standard fading profile (User Defined Path Config), all you need to do is to select the correct Channel Simulator Configuration. Baseband Studio software will set up all of the correct parameters including number of paths, delays, and Doppler shifts as specified by standard. The standard channel simulator configurations are excepted on page 51.

6. Click Apply Needed (it may take a few seconds for this action to complete). Clicking Apply Needed transfers the settings for parameters such as Cell Power and External AWGN to the test set.



Faded Test Example Procedures



On the Test Set:

1. Press the **LOCAL** key  to enable front panel operation.

2. Set FTAP Rate to 38.4 Kbps for Test 1.

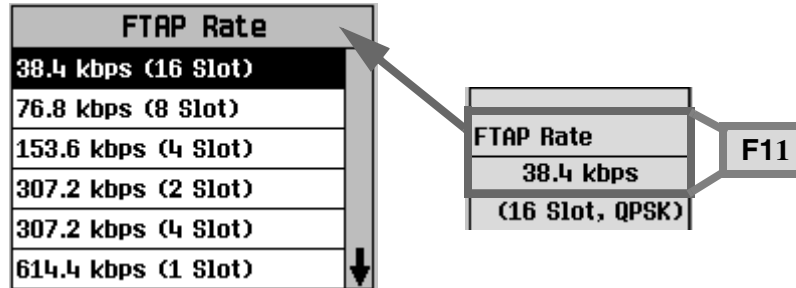
(Press the **CALL SETUP** hardkey, then Press the **F11** (FTAP Rate) key from Call Params 1 of 3 menu).



To perform step 6 from section 3.1.1.2.2.2 follow the instructions in the  and  boxes that follow.

- 5. Once the connection is established, set the test parameters for Test 1 as specified in Table 3.1.1.2.2.2-1.
- 6. From the number of packets transmitted and the number of bad packets received calculate the PER for this test.

 On the Test Set:

- 1. Initiate the Packet Error Rate measurement.
(Press the **Measurement Selection** key, scroll down and select Packet Error Rate.)

Loc	Measurement Selection
	Access Probe Power
	Channel Power
	Digital Average Power
	Waveform Quality + Code Domain
	Packet Error Rate
	TX Spurious Emissions
	Time Response of Open Loop Power Control
	TX Dynamic Power

- 2. Select Packet Error Setup (**F1**). Set the measurement parameters as required for the Test 1. See the following pages for details.

Faded Test Example Procedures

To perform the Test 1 as the following test requirements, follow the instructions in the gray box.

3.1.1.2.2.3 Minimum Standard

The actual power uncertainty due to fading shall be less than or equal to 0.2 dB (see 14.2) with the minimum test duration meeting the requirements specified in Table 12.2-1. Test durations must be sufficient to meet confidence level requirements.

A minimum confidence level of 95% shall be obtained for the following PER requirements (see Section 12).

Case 1:

The actual E_b/N_t used in each test shall be within ± 0.5 dB of the value indicated in Table 3.1.1.2.2.2-1 and Table 3.1.1.2.2.2-2.

The PER for each test shall not exceed the piece-wise linear PER curve specified by the points in Table 3.1.1.2.2.3-1.

Table 12.2-1. Minimum Test Duration Requirements

Band Class	Channel Simulator Configuration							
	1		3		4		6	
	seconds	slots	seconds	slots	seconds	slots	seconds	slots
5 and 11	50	30000	30	18000	3	1800	300	180000
0, 2, 3, 7, 9, 10 and 12	30	18000	20	12000	2	1200	200	120000
1, 4, 6 and 8	10	6000	7	4200	2	1200	70	42000

One slot corresponds to 1.66... ms.

Tip:

The Test Duration Requirements ensures that the PER test runs for a sufficient length of time to allow fading statistics to average out (mean power standard deviation must be less than 0.2 dB).

Table 3.1.1.2.2.3-1. Minimum Standards for Forward Traffic Channel Performance in Fading Channel (Case 1)

Rate	E_b/N_t [dB]	PER
38.4 kbps	(1): 6.84 (2): 5.29	0.05
	(1): 7.29 (2): 6.02	0.03
	(1): 8.85 (2): 7.47	0.01
	(1): 9.59 (2): 8.51	0.005
	(1): 10.3 (2): 9.01	0.003

Faded Test Example Procedures

On the Test Set:

1. Select Packet Error Setup (**F1**).
2. Set Trigger Arm to Single. (NOTE: If you select single trigger mode, press the **START SINGLE** key to start the PER measurement.)
3. Set the Confidence Level to 95.00% as specified in the test requirements.
4. Set the Minimum Packet Count to 375. (Table 12.2.1 specifies the minimum test duration as 600 slots for channel simulator configuration Case 1, which corresponds to 375 packets at 38.4 kbps (each 38.4 kbps packet requires 16 slots to send).)
5. Set PER Requirement to 3.00%. (Table 3.1.1.2.2.3-1 specifies the PER requirement is 3% for Test 1 which requires channel simulator configuration Case 1, traffic data rate at 38.4 kbps.)

Packet Error Rate Setup	Value
Confidence Level	95.00 %
PER Requirement	3.00 %
Minimum Packet Count	375
Maximum Packet Count	10000
Control Channel Data Rate	38.4 kbps
AT Directed Packets	50 %
Trigger Arm	Single
Measurement Timeout	Off

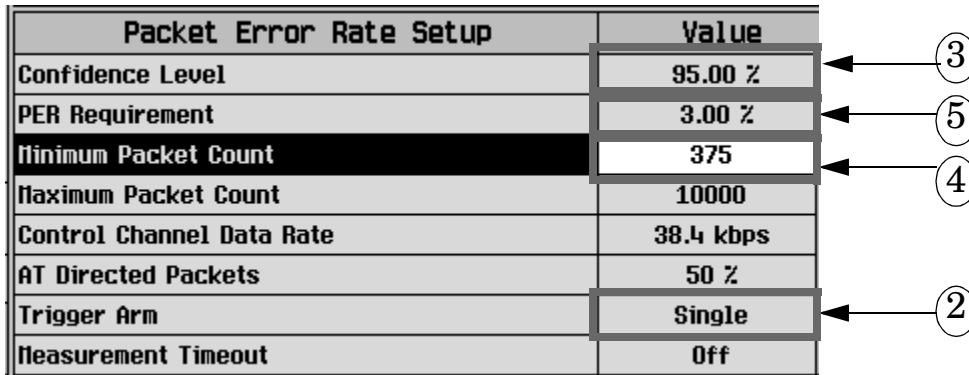

6. Press the **START SINGLE** key to start the PER measurement. (It takes several minutes for the PER measurement to complete.)
7. Verify that the PER measurement is passed.

Packet Error Rate	
Confidence	PER
Pass	0.23 %
Packet Error Count:	1
Packets Tested:	438
Maximum Packet Count:	10000
Eb/Nt:	6.02 dB
PER Requirement:	3.00 %
Single	

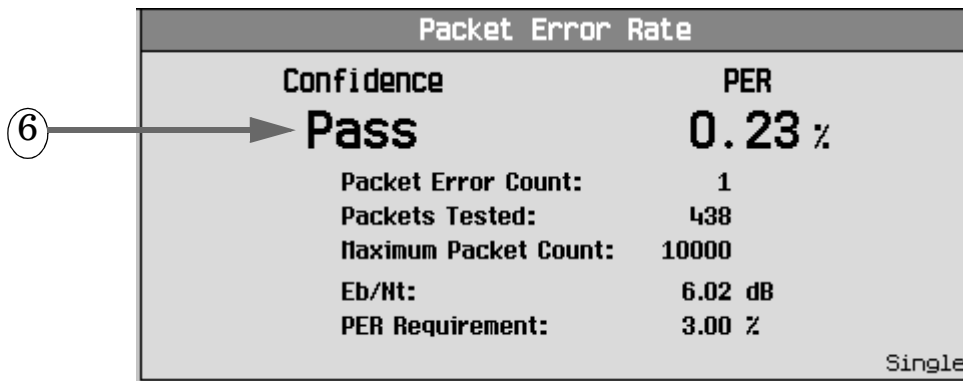

To perform Tests 2 through 24 as specified in section 3.1.1.2.2.2, repeat the procedures above and set the parameters properly.

Fader System Requirements

This section provides background operating information and theory of operation for the E5515C Fading Solution (fader).

Critical Fading Solution Settings

Because the fader integrates a PC software application with hardware residing on both the PC and the test set, the fader must function as a test system. During fading, the PC functions as the system controller, sending GPIB commands to the test set.

After the PC has remotely configured the test set for fading, critical settings must not be overridden by manual test set via front panel operation.

Critical settings on the test set

The following settings are set *automatically* by the Baseband Studio software via GPIB when the fader is turned on. If these settings are changed using the test set's front panel controls, the test set will not generate an accurate faded signal.

When the fader is on, the following settings must be preserved:

- AWGN = Off. If AWGN is desired, it must be enabled using the fading software. If enabled, AWGN will appear in the Ext AWGN Power fields.

Internal AWGN Generator = Off →	Gen Info	Generator Information			External AWGN from Software ←
	Cell 2 Power	Generated Power Level Information			
	Off				
			<u>Current Level</u>	<u>Desired Level</u>	
	Code Channel Parameters	Cell 1 Power (dBm/1.23 MHz):	-50.74	-50.74	
	Cell 2 Power (dBm/1.23 MHz):	Off	Off		
	AWGN Power (dBm/1.23 MHz):	Off	Off		
	Ext AWGN Power (dBm/1.23 MHz):	-63.00	-63.00		
AWGN Power	Total RF Power (dBm/1.23 MHz):	-50.49	-50.49		
Off					
	Channel	Cell 1	Cell 2		

- Bbio Control Digital Bus Path mode = Tx Out + Tx In.

Bbio Control	
Digital Bus Path	← TX Out + TX In
TX Out + TX In	
ALC Mode	
Open Loop	

Fader System Requirements

- The Bbio Control ALC mode must be Open Loop.

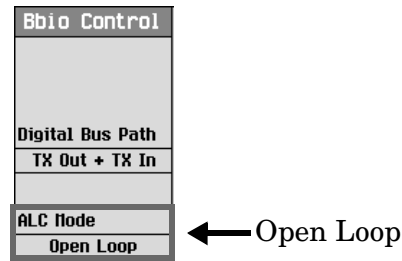

In addition, the test set's Operating Mode must remain set to "Active Cell". This setting is not controlled by the Baseband Studio software.

Critical settings on the Baseband Studio for Fading software

The only critical setting on the fader software is the Fader On/Fader Off buttons. *Once the fader is turned on, it should not be turned off until the call is ended.*

DO NOT CHANGE THIS SETTING DURING A CALL!

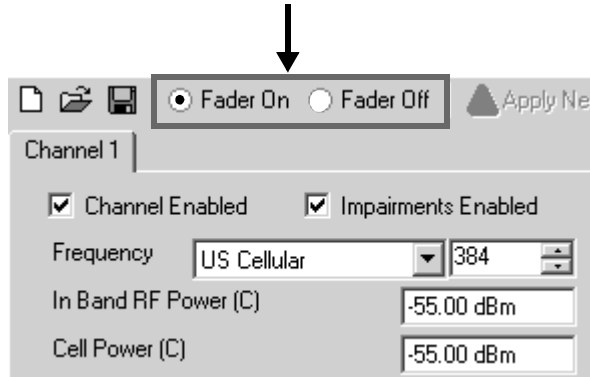

Turning the fader off will cause a momentary loss of the signal from the test set and the call to drop. To enable/disable fading during a call select/clear the Impairments Enabled checkbox

Power Level Control During Fading

This section, “Power Level Control During Fading” , provides background information pertaining to the fader’s power level control. It will help you understand the fader’s output signal generation and some of the limitations that can cause the overrange error to be displayed.

When the fader is turned on, the test set’s signal level is controlled differently than when the fader is turned off. Even though all of the necessary configuration changes to the test set are made automatically by the fader software via GPIB, in some cases it may be useful to understand how power levels are affected when the fader is turned on.

Level Accuracy

Normally, the test set uses an automatic level control (ALC) loop to compare detected power with a reference level and feed back the difference to the RF modulator to correct any error.

During faded signal tests, however, the test set’s ALC loop must be open (disabled). This is because the test set’s ALC loop would interpret the effects of fading as signal level error. If the ALC loop were not opened, the faded signal would be distorted since the ALC bandwidth is much wider than the relatively narrow bandwidth of typical fading patterns.

When the ALC loop is open, a calibration routine must be performed by the user to provide output level accuracy. This calibration procedure, called “Open Loop ALC”, covers the range of frequencies generated by the test set. See “Calibration” on page 70.

Modulation Backoff

Wideband modulation produces inherently high peak-to-average magnitude levels. This is referred to as the modulation’s crest factor. Because of the modulation’s crest factor, Baseband Studio software must scale down the digital I/Q signal power to avoid exceeding the full scale (DAC) range. This provides headroom for signal peaks that result from the modulation type.

Modulation Back Off (MBO) is the parameter that Baseband Studio software receives from the test set for the purpose of scaling down digital I/Q signal for the effects of the particular modulation type’s crest factor.

For example, when the cdma2000 lab application is running and the System Type is IS-2000, MBO will be 18 dB.

Figure 4. Modulation Backoff for System Type cdma2000

Baseband Studio Summary		
Baseband Studio Status:	Impairments On	
Modulation Backoff:	18.00 dB	
Modulation Bandwidth:	1.28 MHz	
	<u>Current</u>	<u>Desired</u>
Impairments Backoff:	16.01 dB	16.01 dB

Impairments Backoff

Depending on the type of fading, further down-scaling is required. This is referred to as Impairments Backoff (IBO).

Based on the fading profile, the fader software calculates IBO. The fader software scales down the unfaded baseband signal by this factor and then multiplies the resulting signal with the complex fading vector.

Fader System Requirements

For example, the standard fading configuration for cdma2000 mobile station test Case 1 would result in an IBO of 16.01 dB.

Figure 5. IBO for a 2-Path Rayleigh Fading Profile with 6.5 Hz of Doppler Spread

Baseband Studio Summary		
Baseband Studio Status:	Impairments On	
Modulation Backoff:	18.00 dB	
Modulation Bandwidth:	1.28 MHz	
	<u>Current</u>	<u>Desired</u>
Impairments Backoff:	16.01 dB	16.01 dB

Output Power Limits

After fading has been applied to the baseband signal, the test set receives the scaled down baseband signal and must then scale the signal up in power to compensate for both backoffs, MBO and IBO. Whether or not the test set will have the output power range required will depend on the amount of backoff associated with the fading profile selected and the requested power level.

If an RF Power level is requested that exceeds the test set's maximum output power limit, the IBO value cannot be applied without overranging the test set's full scale value. In this case, the test set will transmit the highest power level possible considering the IBO required to return the baseband signal to full range while maintaining the requested Eb/Nt ratio. The following error message will indicate that an over range occurred.

The screenshot shows two summary screens. The top screen, 'Baseband Studio Summary', displays the following data:

Baseband Studio Summary		
Baseband Studio Status:	Impairments On	
Modulation Backoff:	18.00 dB	
Modulation Bandwidth:	1.28 MHz	
	<u>Current</u>	<u>Desired</u>
Impairments Backoff:	15.74 dB	16.74 dB

The bottom screen, 'Digital Bus Summary', shows:

Digital Bus Summary	
Symbol Rate:	1.22880 MSym/s
Clock Rate:	12.28800 MHz

A warning message box is overlaid on the bottom screen, with an arrow pointing to the 'Desired' IBO value in the table above. The warning text reads: 'Warning: Impairments backoff (IBO) over range due to settings made under external software control'.

On the Baseband Studio Summary screen above, the Desired Impairments Backoff value indicates the IBO associated with the requested RF Power level. The Current IBO value indicates the value associated with the current maximum power level attainable.

The difference between the Desired (actual) Impairments Backoff value and the Current (maximum obtainable) Impairments Backoff is displayed. The difference between the Current and Desired Impairments Backoff reflects the difference between the Current and Desired RF output power. These values are reported in the Generated Power Level Information screen.

Generated Power Level Information					
		Current Level	Desired Level		
Cell 1 Power (dBm/1.23 MHz):		-26.74	-25.74		
Cell 2 Power (dBm/1.23 MHz):		Off	Off		
AUGN Power (dBm/1.23 MHz):		Off	Off		
Ext AUGN Power (dBm/1.23 MHz):		-34.74	-33.74		
Total RF Power (dBm/1.23 MHz):		-26.10	-25.10		
Channel	Cell 1		Cell 2		
	PN Offset:	12	PN Offset:	36	
	Level (dB)	Walsh	Level (dB)	Walsh Code	
F-Pilo	<div style="border: 1px solid black; padding: 5px; text-align: center;"> Warning: Impairments backoff (IBO) over range due to settings made under external software control </div>				0
F-Sync					
F-Pagi					
F-QPC					
F-FCH					
F-SCH		10			
F-OCNS			53		

Fader System Requirements

Calibration

ALC Open Loop Calibration

In addition to the same calibrations required for non-fader operation, there is one additional calibration routine required for accurate faded signals. It is called ALC Open Loop Calibration.

When the fader is on, the test set's ALC (Automatic Level Control) loop is disabled. The ALC loop normally measures output power, continually applying correction values to the output level through a feedback loop. If allowed to operate in the closed loop mode, level changes introduced by signal fading would essentially be canceled out.

The method used to obtain calibrated output levels on faded signals is called "Open Loop ALC". In this mode, the ALC path is opened and corrections applied to the output signal level are obtained from calibration tables in the test set's memory. These tables are built during the ALC Open Loop Calibration. ALC open loop calibration values provide level correction across the complete frequency range of the test set.

The Open Loop ALC calibration routine must be run initially before performing faded tests. The test set should be allowed to warm up at least a two hours for the internal temperatures to stabilize. After the initial calibration, Open Loop ALC should be run about every six months or when the test set's internal temperature changes more the +/- 5 degrees C from the temperature during the last calibration. A temperature sensor inside the test set detects when +/- 5 degrees C of temperature drift has occurred and displays a message on the front panel.

Open Loop ALC is accessed through the Digital Bus Info field (left 3 of 4 Call Control menu). The entire process takes about two minutes. Call processing is disabled during this time.

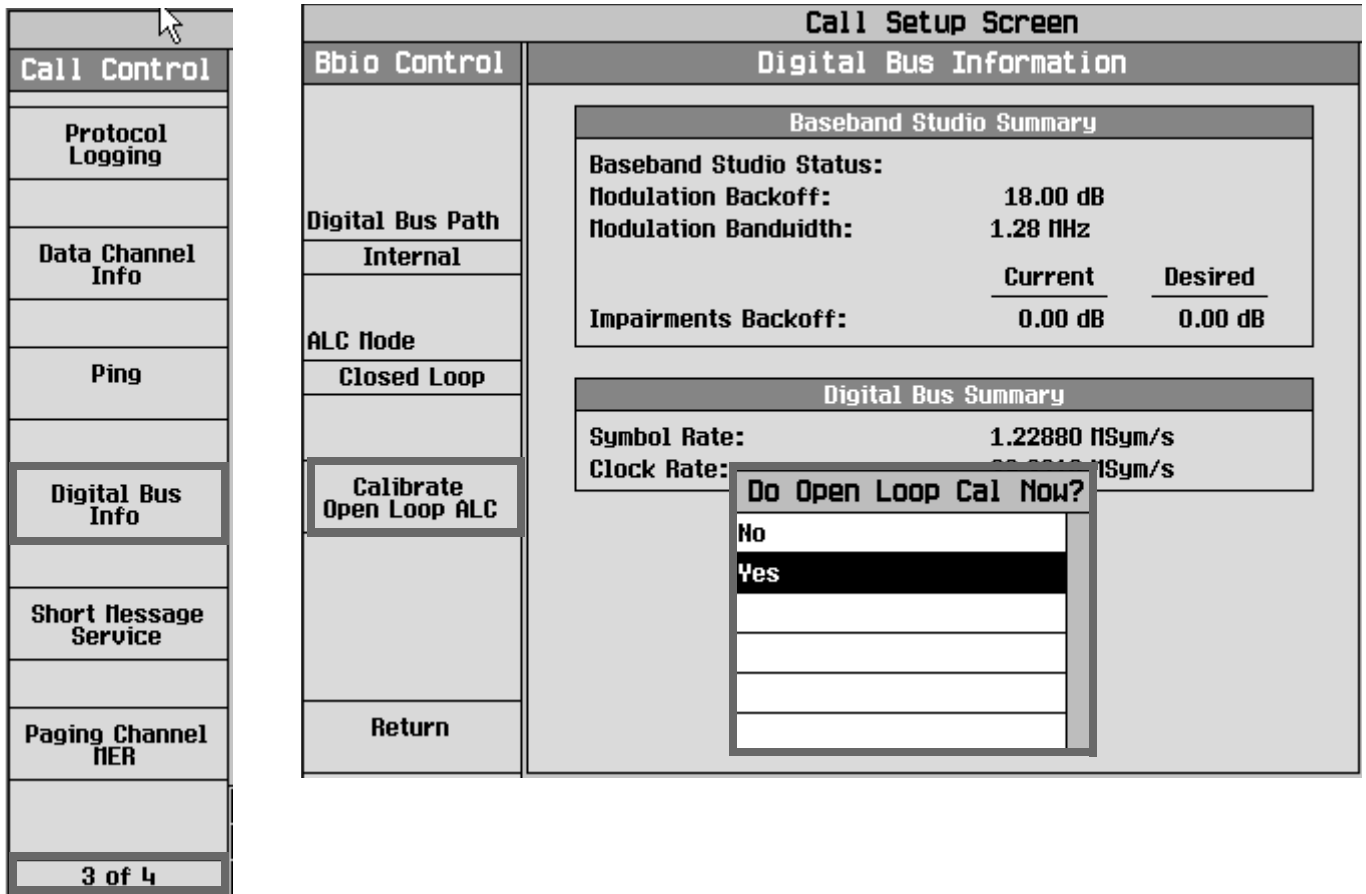

I/Q Calibration

When fading is applied to the baseband signal, signal levels can momentarily drop to levels far below the average level. This drop in signal level is referred to as a deep fade, and can result in levels that approach the minimum power level the test set is capable of generating.

The test set's lower power limit is determined by carrier leakage and residual broadband noise. Residual noise is always present, but carrier leakage caused by DC offsets in the analog baseband I/Q circuitry can be calibrated out by running the IQ calibration routine. This will ensure that the range of power levels generated by the test set extends to the lowest possible levels.

I/Q calibration, like Open Loop ALC, should be performed initially after the test set is fully warmed up and again if the operating temperature has drifted more than 5 degrees C since the last I/Q calibration.

The Cal. first IQ Modulator procedure is accessed through the System Config, Service field (right 2 of 2 Utilities menu). This calibration process takes about 10 minutes. Call processing is disabled while the calibration is in progress

NOTE Performing Cal. second IQ Modulator is not necessary for faded signals. It applies to the test set's second RF source which is not faded.

Fader System Requirements

System Config Screen																																						
Control		Configuration Summary						Utilities																														
Instrument Setup ▾	<table border="1"> <thead> <tr> <th colspan="3">Instrument Information</th> </tr> </thead> <tbody> <tr> <td>Application:</td> <td colspan="2">CDMA 2000 Lab App B</td> </tr> <tr> <td>PRE-RELEASE</td> <td>E6702B</td> <td>B.02.01</td> </tr> <tr> <td>Format:</td> <td colspan="2">IS-2000/IS-95/AMPS</td> </tr> <tr> <td>GPIO Address:</td> <td colspan="2">14</td> </tr> <tr> <td>Lan IP Address:</td> <td colspan="2">130.29.183.121</td> </tr> <tr> <td>Subnet Mask:</td> <td colspan="2">255.255.0.0</td> </tr> <tr> <td>Default Gateway:</td> <td colspan="2">130.29.184.1</td> </tr> <tr> <td>Last Calibration:</td> <td colspan="2">01 Jan 0000</td> </tr> <tr> <td>Serial Number:</td> <td colspan="2">US00000097</td> </tr> </tbody> </table>						Instrument Information			Application:	CDMA 2000 Lab App B		PRE-RELEASE	E6702B	B.02.01	Format:	IS-2000/IS-95/AMPS		GPIO Address:	14		Lan IP Address:	130.29.183.121		Subnet Mask:	255.255.0.0		Default Gateway:	130.29.184.1		Last Calibration:	01 Jan 0000		Serial Number:	US00000097		Service	
	Instrument Information																																					
Application:	CDMA 2000 Lab App B																																					
PRE-RELEASE	E6702B	B.02.01																																				
Format:	IS-2000/IS-95/AMPS																																					
GPIO Address:	14																																					
Lan IP Address:	130.29.183.121																																					
Subnet Mask:	255.255.0.0																																					
Default Gateway:	130.29.184.1																																					
Last Calibration:	01 Jan 0000																																					
Serial Number:	US00000097																																					
Format Switch ▾							Self Test																															
Application Selection	<table border="1"> <thead> <tr> <th colspan="3">Service</th> </tr> </thead> <tbody> <tr> <td>Options</td> <td>Cal. first IQ Modulator</td> <td>Sense Status</td> </tr> <tr> <td>002 RF Source</td> <td>Cal. second IQ Modulator</td> <td>A rev B L</td> </tr> <tr> <td>003 Flexible R</td> <td>Cal. Burst Mod Offset 1</td> <td></td> </tr> <tr> <td>004 Digital Bus</td> <td></td> <td></td> </tr> <tr> <td></td> <td></td> <td></td> </tr> <tr> <td></td> <td></td> <td></td> </tr> </tbody> </table>						Service			Options	Cal. first IQ Modulator	Sense Status	002 RF Source	Cal. second IQ Modulator	A rev B L	003 Flexible R	Cal. Burst Mod Offset 1		004 Digital Bus																			
	Service																																					
Options	Cal. first IQ Modulator	Sense Status																																				
002 RF Source	Cal. second IQ Modulator	A rev B L																																				
003 Flexible R	Cal. Burst Mod Offset 1																																					
004 Digital Bus																																						
RF IN/OUT Amptd Offset																																						
1 of 2		<table border="1"> <tr> <td>Active Cell</td> <td colspan="2">Sys Type: IS-2000</td> </tr> <tr> <td>Idle</td> <td colspan="2">Logging: No Conn.</td> </tr> </table>				Active Cell	Sys Type: IS-2000		Idle	Logging: No Conn.		2 of 2																										
Active Cell	Sys Type: IS-2000																																					
Idle	Logging: No Conn.																																					
	DBUS-INT	IntRef																																				

The Digital Bus Connection

The digital bus carries digital baseband signals between the N5101A PCI card installed in the PC and the test set's rear panel digital bus interface.

Digital Bus path control in the test set

A test set equipped with Option 504 includes a rear panel with an 80-pin connector labeled Digital Bus and a BBIO (Baseband Input/Output) circuit board that provides the necessary baseband I/Q signal path switching.

The correct path switching mode is automatically set by the fader software when fading is turned on or off. In addition to the path switching modes used for faded and non-faded operation, there are two path switching modes that are provided for diagnostic purposes. Before changing any Digital Bus Path settings, see "Critical Fading Solution Settings" on page 65.

The Digital Bus Path menu consists of the following settings:

- Internal - For normal non-faded operation. Routes the test set's digital I/Q signal to the analog I/Q circuitry. See Figure 6. "Digital Bus Path Control = Internal".
- TX Out + TX In - For normal faded operation. Sends digital I/Q data from the test set to a PC via the Digital Bus output and routes the Digital Bus data input from a PC to the test set's analog I/Q circuitry. See Figure 7. "Digital Bus Path Control = TX Out + TX In".
- Diag Loopback - Used for testing path switching internal to the test set. Transmitted digital I/Q data bits are routed back to the digital I/Q receiver. No data is sent to/from the Digital Bus.
- Ext Loopback - Used for testing external (N5101A PCI card) hardware. Routes the data input from the PC to the Digital Bus back to the PC via the Digital bus output. This is used when the "Run Self Tests for Selected Item" button is selected from the System Configuration window (see "Configuring the Fader System" on page 13).
- TX Output Only - Reserved for future use.
- TX Out + I Data - Reserved for future use.
- TX Out + Q Data - Reserved for future use.

Figure 6. Digital Bus Path Control = Internal

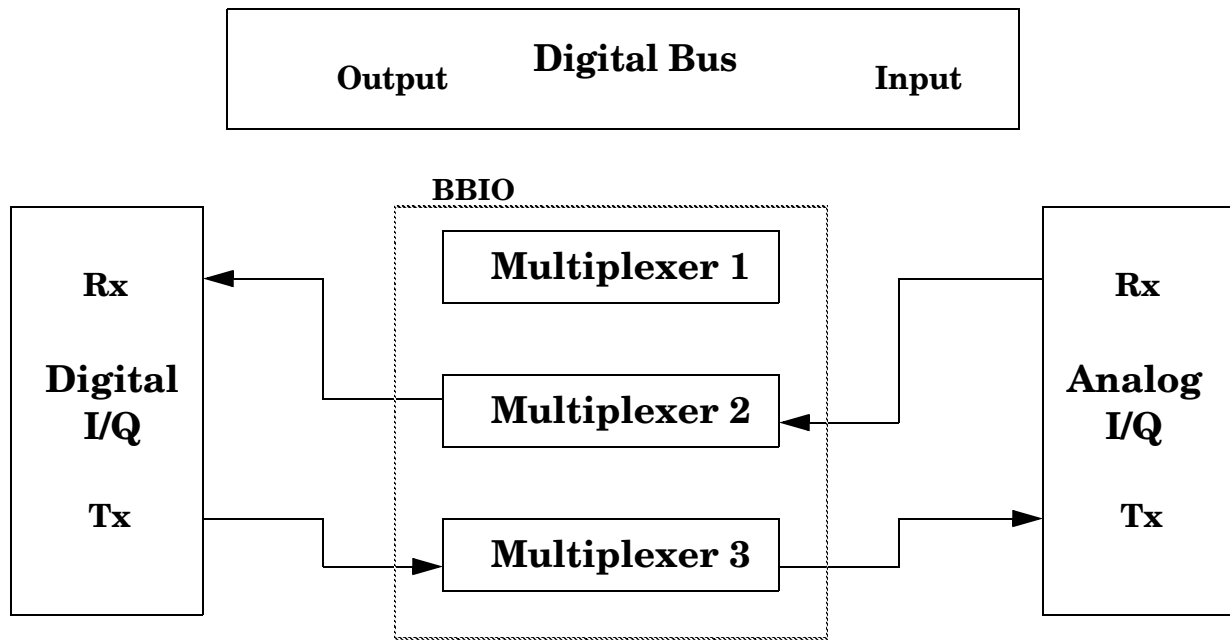

Figure 7. Digital Bus Path Control = TX Out + TX In

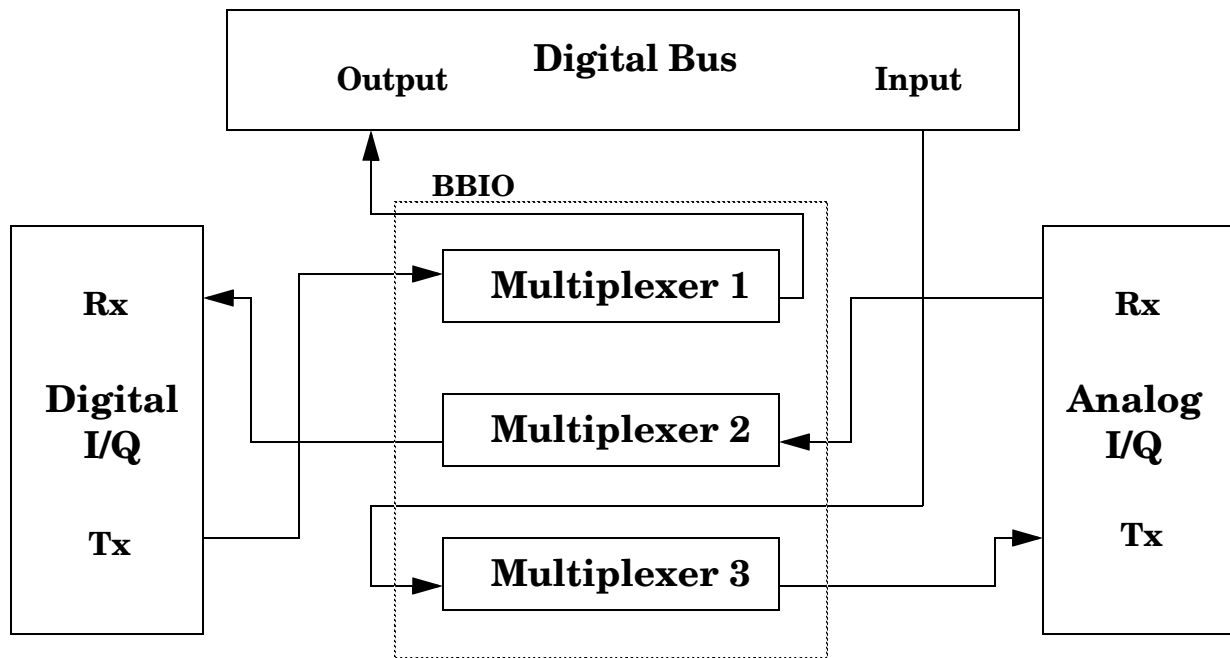
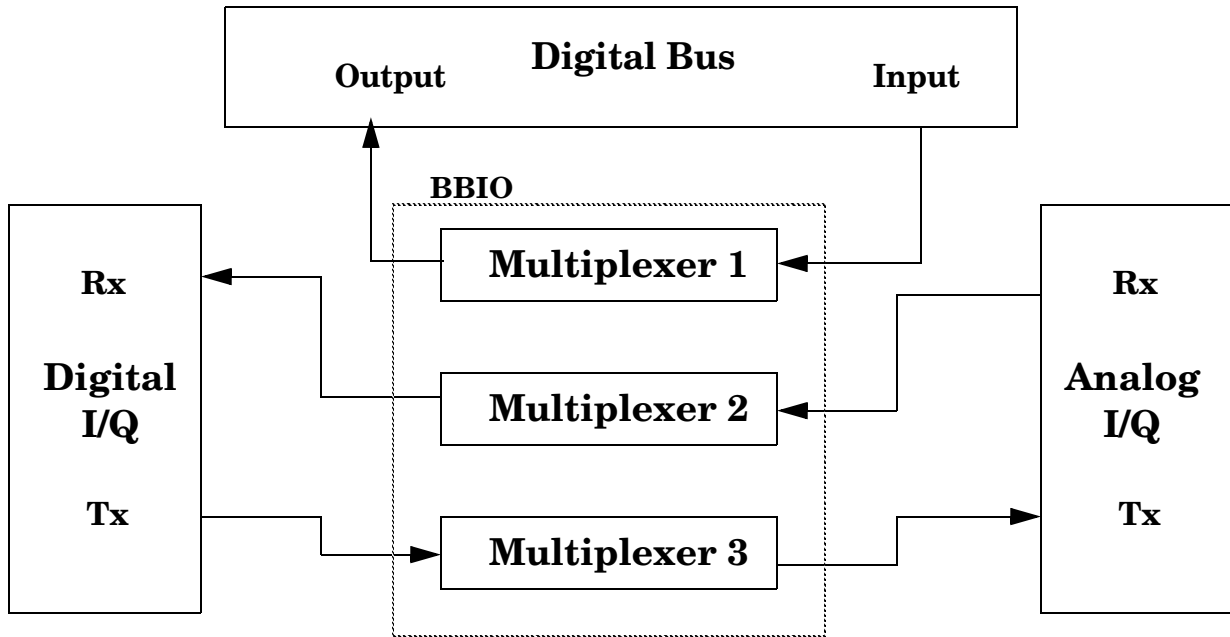

Figure 8. Digital Bus Path Control = Ext Loopback



Output Power

The RF Out Only connector, available on test sets with two RF ports, provides a higher output power than the RF In/Out. By externally duplexing the RF input and output, you can take advantage of the higher output power available at the RF Out Only connector. This will result in approximately 8 dB of increased cell power and 3 dB of increased AWGN power.

See the following data sheets for CDMA and W-CDMA output power specifications:

- Agilent E6702B cdma2000/IS-95/AMPS Mobile Lab Application Data Sheet
<http://cp.literature.agilent.com/litweb/pdf/5988-6180EN.pdf>
- Agilent E6703B W-CDMA Lab Application Data Sheet
<http://cp.literature.agilent.com/litweb/pdf/5989-0248EN.pdf>

Fader System Requirements

Figure 9. RF Setup using RF Out Only Port

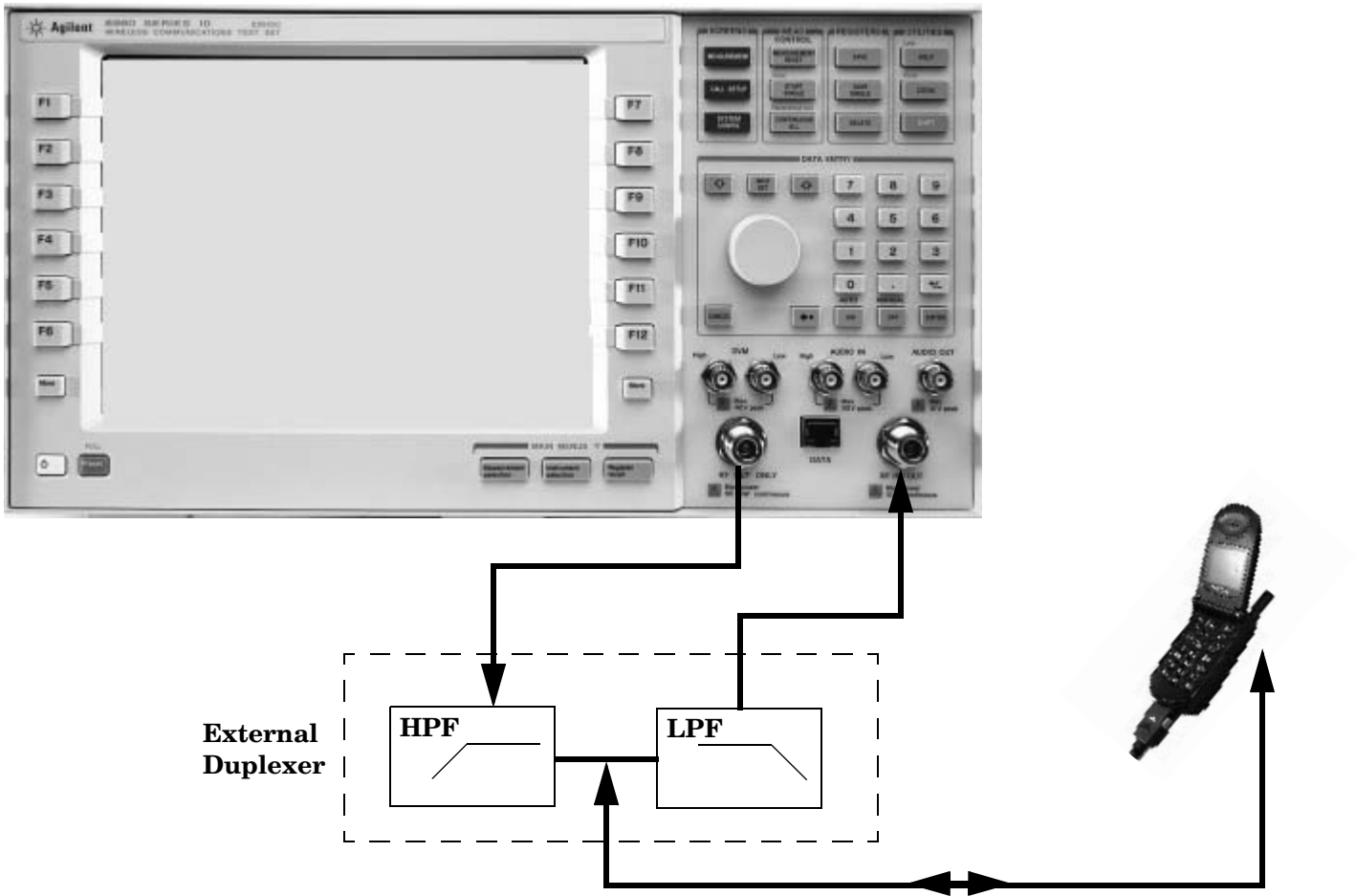

W-CDMA Transmitter Measurement Considerations

Some of the test set's transmitter measurements will not provide valid results while on a faded channel. To perform these transmitter measurements, you must end the connection between the test set and UE, then click on Fader Off on the fading software, then re-establish the connection and perform the desired transmitter tests. The table below indicates which transmitter measurements are available while fading is on.

Table 1. W-CDMA Transmitter Measurement Availability on Faded Channel

Measurement	Available on Faded Channel?	Requirements	Considerations
Adjacent Channel Leakage Ratio	Yes	Trigger Source must be set to Immediate or External.	
Audio Analyzer	N/A		
Data Throughput Monitor	Yes		
Audio Generator	N/A		
Change of TFC	No		
Channel Power	Yes	Trigger Source must be set to Immediate or RF Rise.	
Code Domain	Yes	Trigger Source must be set to Immediate or External.	Timing Error measurement result is not available when Trigger Source is set to Immediate.
Dynamic Power Analysis	Yes		
Frequency Stability	N/A		
Inner Loop Power	No		
IQ Tuning	Yes	Trigger Source must be set to Immediate or External.	Timing Error measurement result is not available when Trigger Source is set to Immediate.
Occupied Bandwidth	Yes	Trigger Source must be set to Immediate or External.	
Out-of-Synch Handling of Output Power	No		
Phase Discontinuity	Yes	Trigger Source must be set to External.	
PRACH Preamble Analysis	Yes	Trigger Source must be set to External or RF Rise.	Timing Error measurement result is not available when Trigger Source is set to RF Rise.
PRACH Transmit On/Off Power	No		

Fader System Requirements

Table 1. W-CDMA Transmitter Measurement Availability on Faded Channel

Measurement	Available on Faded Channel?	Requirements	Considerations
Spectrum Emission Mask	Yes	Trigger Source must be set to Immediate or External.	
Spectrum Monitor	Yes	Trigger Source must be set to Immediate, RF Rise, or External.	
Swept Audio	N/A		
Thermal Power	Yes		
Waveform Quality	Yes	Trigger Source must be set to Immediate or External.	Time Error measurement result is not available when Trigger Source is set to Immediate.

Position Location

The E5515C with option E5515CU - 504 installed for the fader is not compatible with the R1431A and E5515C H16 gpsOne calibration.

If the E5515C has been calibrated for gpsOne with either:

- Local service center R1431A or
- a new purchase with E5515C option H16

the calibration data uncertainty will be degraded from +/-17 nS to +/-30 nS.

The gpsOne testing itself is not effected by fader options. Only the certainty of the gpsOne data is degraded. If the uncertainties are determined by the user to be acceptable, gpsOne testing can still be valid. Agilent, however, will not specify or support gpsOne operation on instruments that have E5515CU option 504 installed.

R1431 re-calibration of the E5515C with E5515CU option 504 is not supported.

Fader System Requirements

GPIB Configuration

The fading software controls some test set functions via GPIB. When using the fading software System Configuration Add Wizard you are prompted for a Board Index, Primary Address, and Secondary Address. The correct values for these fields will depend upon your GPIB driver configuration (for Board Index) and the test set's **SYSTEM CONFIGURATION** screen (for Primary Address).

NOTE The 8960 does not support LAN instrument control. The PC must be configured with GPIB hardware and the required drivers. For easy connectivity with good performance Agilent Technologies recommends the Agilent 82357A USB/GPIB Interface. See www.agilent.com/find/gpib.

When using the Agilent 82357A, you can determine the Board Index by clicking the “IO” icon on the Windows task bar, and selecting Run IO Config. In the Agilent IO Libraries Configuration dialog the VISA (Interface) Name contains the Board Index number.

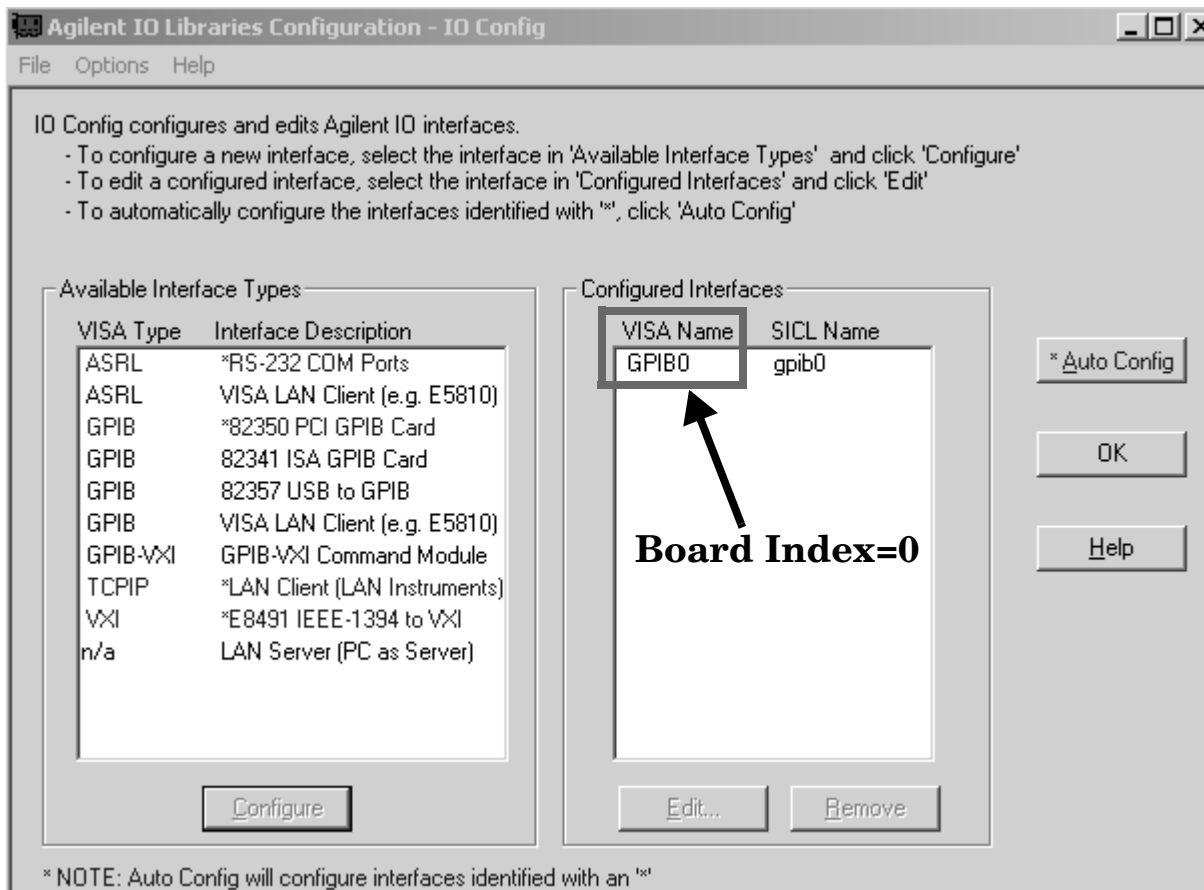

Troubleshooting

The E5515C Fading Solution (fader) integrates signal processing hardware in a PC with the E5515C test set's signal generator. Most of the problems associated with fader operation involve setting incompatibility that results when Baseband Studio for Fading software (fading software) control of the test set is overridden.

Refer to the “Critical Fading Solution Settings” on page 65 for a description of settings that must be preserved during faded signal testing.

Known Issues

Call processing errors resulting from turning the fader on or off during a call.

The procedures given in the “Faded Test Example Procedures” on page 24 provide a step-by-step example of fader operation.

During these procedures, the fader is always turned on before a call is made. Once a call is connected, *the fader must remain on.*

DO NOT CHANGE THIS SETTING DURING A CALL!

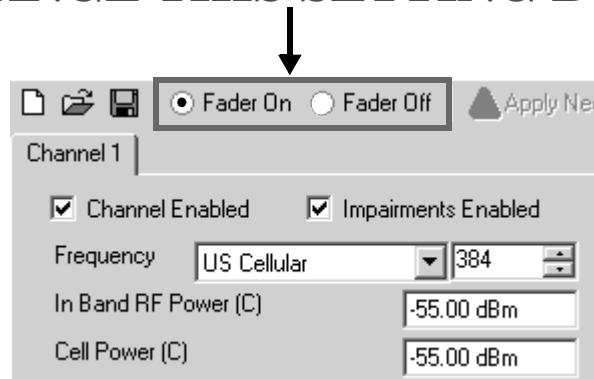

Turning the fader off will cause a momentary loss of the signal from the test set and the call will drop. If you would like to disable fading during a call, clear the Impairments Enabled checkbox and click the Apply Needed button.

Loss of synchronization during handoffs.

Handoffs, such as RF channel and PN offset hard handoffs, can cause frame clock synchronization problems between the test set and the Baseband Studio for Fading software. It is recommended that performing handoffs be avoided while the fader is on.

Some W-CDMA Transmitter Measurements Not Available in Faded Configuration

Some of the test set's transmitter measurements will not provide valid results while on a faded channel. See “W-CDMA Transmitter Measurement Considerations” on page 77 for more information.

Troubleshooting

Other Considerations

- It is recommended that you perform call processing operations (such as establishing a call and changing RMCs) without channel impairments, to ensure that the UE is able to receive and properly decode the signaling from the test set.

Error Messages

The following test set error messages can occur during fader operation:

NOTE Refer to the online Help for fading software error messages that appear on the PC.

Table 2. Test Set Error Messages

Error Message	Cause	Recovery
Operation rejected; Setting is currently under external control	This error is displayed when an attempt is made to set something on the front panel of the test set that is settable from the fading software. Examples are Cell Power, Cell Band, and Channel settings.	Perform these operations using the controls on the PC's fading software.
Warning; Impairments backoff (IBO) over range due to settings made under external software control	The test set does not have sufficient power range to generate the power level requested.	Reduce the RF Power level or AWGN using the PC's fading software settings.

Checking Fader Hardware Connectivity

There are several diagnostic routines that can be run to check fader system connectivity.

The diagnostic routines and conditions for running them are listed in Table 3.:

Table 3. Fader Connectivity Diagnostics

Diagnostic	Typically run when...	Runs From the...	Automated?	Notes
PCI Card Connectivity 1	Adding a new system configuration (using System Configuration Add Wizard)	Baseband Studio System Configuration Menu	Yes	Button label is "Run Self Tests for Selected Item"
PCI Card Connectivity 2	PCI Card Connectivity #1 fails	Baseband Studio System Configuration Menu	Partially	User is prompted to install loopback fixture.

Table 3. Fader Connectivity Diagnostics

Diagnostic	Typically run when...	Runs From the...	Automated?	Notes
Verification of the Communication Test Set	Option 504 (Baseband IO board and rear panel) is first installed.	Test Set	No	User is prompted to install loopback fixture and configure the test set to analyze transmitted signal on internal spectrum monitor
PCI Connectivity 3		Baseband Studio	Yes	Future enhancement that will fully test path from PCI card through test set switching paths and back to PCI card.

Related Documentation

The fader includes the following documents

- N5101A Baseband Studio PCI Card Installation Guide (provides instructions on how to set up a PC and the test set to run fading software). This document is P/N N5101-90001 and is available in pdf format. For downloading, go to www.agilent.com/find/basebandstudio.
- Baseband Studio for Fading Online Help (provides reference information describing controls in the fading software). This help utility is accessible through the Help menu in the fading software.
- E5515CU Option 504 Installation Guide (provides instructions for installing the Option 504 Back Panel Connector Kit and BBIO Board).